

IntelliGen[®] NCS

Enables LAN connectivity, and provides universal control of dispense pumps in your network

The IntelliGen[®] NCS network communication system allows users to connect IntelliGen dispense systems used in photo-chemical applications to a Local Area Network (LAN). Once connected to a network, you can easily display critical process parameters from the dispense systems on your network, and efficiently collect performance data, from inside or outside the factory, using one or more computers on your network.

Use of this network platform provides a rapid method for accessing, programming, monitoring, and updating up to 12 dispense systems per communication port.

FEATURES & BENEFITS

- Eight com ports built in 1 com port: Maximum 12 pumps connected
- LED screen for better viewing IP address, forced shutdown, restart, etc.
- DIN rail connection

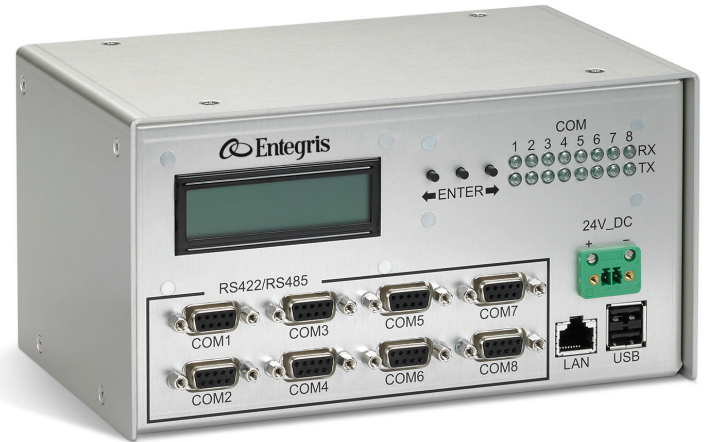

SPECIFICATIONS

PARAMETER	VALUE
Connector port	RS-422/485 port
Number of connector ports	8 communication ports
LAN accessible to network	RJ-45 10/100 Ethernet connection supporting DHCP or static configuration
Network setup	Universal plug and play (UPNP setup)
Power	24V DC (±10%)
Electricity (current rating)	1.25 A
Serial communication	RS-422
Certificate	CE compliance

DIMENSIONS

Front View

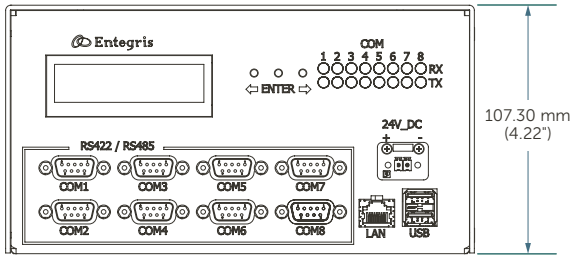

Top View

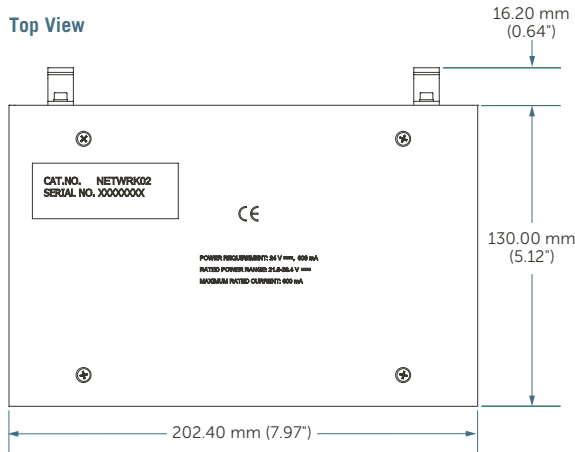

Side View

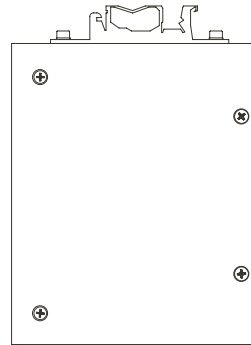

INTELLIGEN NCS INTERFACE CONNECTIONS

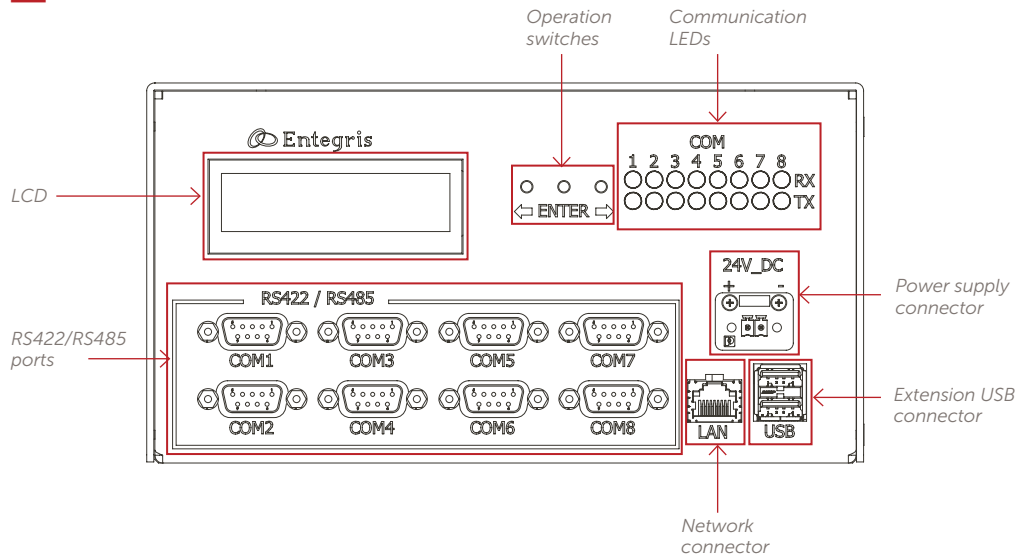

SYSTEM SCHEMATIC: FLUID PIPING, UTILITY, AND ELECTRICITY

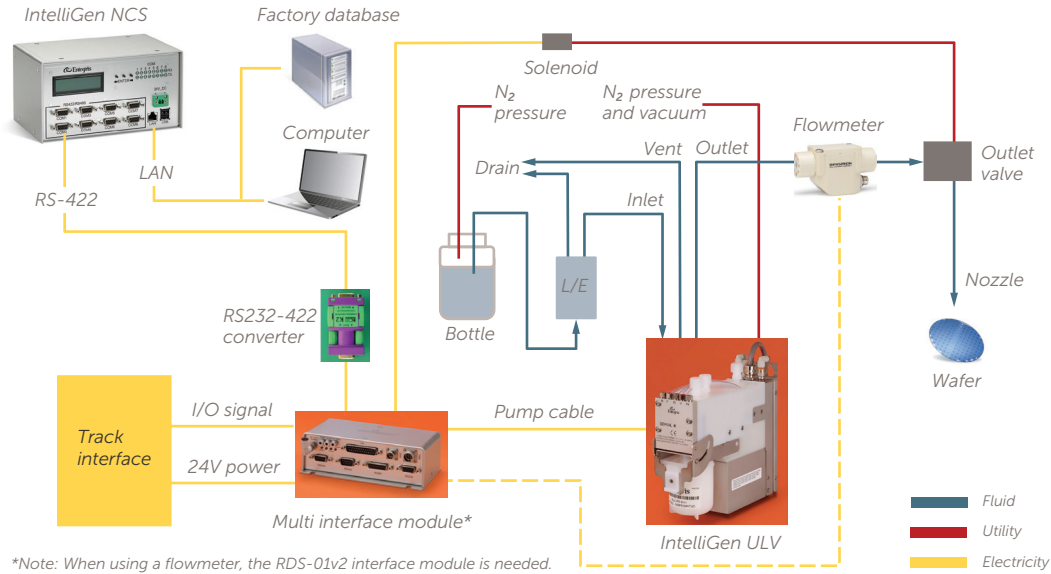

ORDERING INFORMATION

Part number	Description
NETWRK02	IntelliGen NCS, network communication system
NETWRK2SP01	AC adapter cable for IntelliGen NCS
NETWRK2SP02	RS-422 extension cable 3 m (118.1") for IntelliGen NCS
NETWRK2SP03	Direct 24V cable for power supply
NETWRK2KIT01	IntelliGen NCS with AC adapter cable kit

FOR MORE INFORMATION

Please call your Regional Customer Service Center today to learn what Entegris can do for you. Visit entegris.com and select the Contact Us link to find the customer service center nearest you.

TERMS AND CONDITIONS OF SALE

All purchases are subject to Entegris' Terms and Conditions of Sale. To view and print this information, visit entegris.com and select the Terms & Conditions link in the footer.



Corporate Headquarters
129 Concord Road
Billerica, MA 01821
USA

Customer Service
Tel +1 952 556 4181
Fax +1 952 556 8022
Toll Free 800 394 4083

Entegris®, the Entegris Rings Design™, Pure Advantage™, and other product names are trademarks of Entegris, Inc. as listed on entegris.com/trademarks. All third-party product names, logos, and company names are trademarks or registered trademarks of their respective owners. Use of them does not imply any affiliation, sponsorship, or endorsement by the trademark owner.

©2018 Entegris, Inc. | All rights reserved. | Printed in the USA | 6362-8478ENT-0218