

NOWPak[®] Canister Closure

Thread-on two-piece stainless steel cap and closure for high-viscosity applications

The NCV-200-T shipping cap and NCV-200-B closure protect critical high-viscosity materials within filled canister systems. The cap and closure are designed for use with the NOWPak[®] Canister System high-viscosity dispense connector. Fits 200-liter NOWPak canisters.

APPLICATIONS

- Polyimide
- Liquid optically clear adhesive
- Applications requiring high flow rates

FEATURES & BENEFITS

- Two-piece design remains sealed until the connector is installed
- Closure is reusable after cleaning



NCV-200-T cap and NCV-200-B high-viscosity closure

SPECIFICATIONS

NCV-200-T Shipping Cap for High-viscosity Connector

This shipping cap is designed to thread onto the NCV-200-B closure for 200-liter canisters to seal the canister prior to shipping.

Neck thread	Buttress 63 mm	
Application torque	27–34 N•m (20–25 ft•lb)	
Materials of construction	Cap body	Stainless steel
	Liquid/fitment seal	Chemraz® o-ring
	Cap seal	FEP-encapsulated silicone

NCV-200-B Closure for High-viscosity Connector

This closure is for use with 200-liter canisters. The closure is threaded onto the canister and then sealed with the NCV-200-T shipping cap, or the high-viscosity connector can be threaded onto the closure for 200-liter applications.

Neck thread	Buttress 4.75–4	
Application torque	47–54 N•m (35–40 ft•lb)	
Materials of construction	Closure body	Stainless steel
	Compression ring	Polypropylene
	Closure o-ring	FEP-encapsulated silicone

Manufacturing standards	Assembled and tested in a Class 5 Cleanroom as per International Standard ISO 14644-1:1999 Cleanrooms and associated controlled environments – Part 1: Classification of air cleanliness.
--------------------------------	---

Cleanliness	Closure assembly to be free from lubricants and other extraneous foreign materials consistent with Entegris' processes and procedures.
--------------------	--

DIMENSIONS

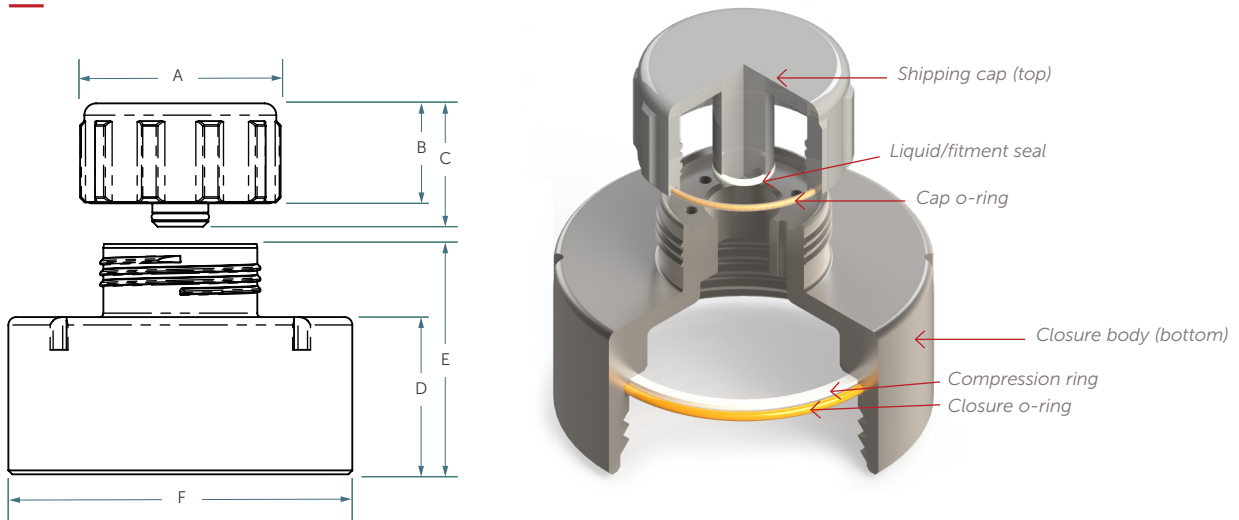

NCV-200-T and NCV-200-B High-viscosity Closure (for use with 200-liter size canisters)

Part number	Description	Dimensions (maximum)		
NCV-200-T	Shipping cap (top)	A	Outside diameter	78 mm (3.1")
		B	Cap height	38 mm (1.5")
		C	Overall height	48 mm (1.9")
NCV-200-B	Closure (bottom)	D	Closure height	61 mm (2.4")
		E	Overall height	89 mm (3.5")
		F	Outside diameter	133 mm (5.3")

SHIPPING INFORMATION

Labeling	The inner bag of each cap/closure assembly is labeled with the part number and batch number. Each corrugated shipping carton is labeled with the part number, batch number, quantity, and date of manufacture.
Packaging	Each cap/closure assembly is individually double-bagged in a heat-sealed, cleanroom-processed PE inner bag and a heat-sealed PE outer bag. Closures are then placed in a corrugated shipping carton lined with bubble wrap.
Part numbers	NCV-200-T or NCV-200-B
Box quantity (minimum order quantity)	1
Box dimension	15.2 cm L x 17.8 cm W x 15.2 cm H (6" L x 7" W x 6" H)

ORDERING INFORMATION

NCV-200-T, NCV-200-B Cap/Closure: part number

NCV - 200 -



High-viscosity Cap/Closure Accessories

Part number	Description
200316	Replacement Chemraz fitment seal for NCV-200-T and NCV-200-T-V, quantity of 1
2100665-C	Replacement FEP-encapsulated silicone o-ring for NCV-200-T, quantity of 1
201075-C	Replacement FEP-encapsulated silicone o-ring for NCV-200-B, quantity of 1
401120-C	Replacement polypropylene compression ring for NCV-200-B, quantity of 1

Note: The recommended o-ring and compression ring replacement timing is approximately 6 months. Actual replacement timing can be impacted by factors such as the chemical used, environmental conditions, and care and handling of the product.

LIMITED WARRANTY

Entegris' products are subject to the Entegris, Inc. General Limited Warranty. To view and print this information, visit entegris.com and select the Legal & Trademark Notices link in the footer. Entegris does not warranty any failure in the case of customers using unapproved foreign components.

FOR MORE INFORMATION

Please call your Regional Customer Service Center today to learn what Entegris can do for you. Visit entegris.com and select the Contact Us link to find the customer service center nearest you.

TERMS AND CONDITIONS OF SALE

All purchases are subject to Entegris' Terms and Conditions of Sale. To view and print this information, visit entegris.com and select the Terms & Conditions link in the footer.



Corporate Headquarters
129 Concord Road
Billerica, MA 01821
USA

Customer Service
Tel +1 952 556 4181
Fax +1 952 556 8022
Toll Free 800 394 4083

Entegris®, the Entegris Rings Design™, Pure Advantage™, and other product names are trademarks of Entegris, Inc. as listed on entegris.com/trademarks. All third-party product names, logos, and company names are trademarks or registered trademarks of their respective owners. Use of them does not imply any affiliation, sponsorship, or endorsement by the trademark owner.

©2018 Entegris, Inc. | All rights reserved. | Printed in the USA | 7124-8526CRE-0218