

# Pharmsteri™ II GSV UPE Vent Capsule Filter

*Delivers superior airflow at low pressure drop with lower blockage risk in moist air sterile filtration*

Sterile venting and gas filtration are critical for various process steps in pharmaceutical and biopharmaceutical manufacturing, to maintain a sterile barrier or ensure process gases or wastes are properly filtered. Entegris is a leading expert in controlling particles and impurities and we are leveraging our expertise and experience in material science and filter manufacturing for strict semiconductor applications into the life sciences market.

Pharmsteri™ II GSV (gamma, sterile venting) UPE Vent capsule filters are made of dual-layer hydrophobic ultra-high molecular weight polyethylene (UPE) membrane with nominal pore rating at 0.22 µm, and a high-grade, gamma-stable polypropylene (PP) shell.

The capsule filters are validated with liquid bacterial challenge test ensuring retention even in humid process conditions. UPE membrane provides high hydrophobicity which contributes to reduced blockage risk under moist air and less airflow drop at longer service time.

## APPLICATIONS

- Single use bioreactor vessels or bags
- Mixer vessels or bags
- Storage or holding vessels or bags
- Filling tube sets or bag assemblies
- Carboys or Bottles assemblies
- Filtration or transfer assemblies
- Integrity test manifolds
- Single use cell therapy devices or assemblies



*Provides high air flow at lower pressure drop*

## FEATURES & BENEFITS

<b>Best-in-class air flowrate</b>	Optimized membrane structure provides high air flow at lower pressure drop while maintaining high retention level
<b>High hydrophobicity</b>	Low blockage risk under humid process conditions and long lifespan
<b>Sterilizing grade meets Bacterial Challenge Test (ASTM F838)</b>	Challenged in liquid, ensures that microorganisms, such as bacteria, are removed from the fluid stream while not adversely affecting product
<b>Gamma irradiation compatible</b>	Gamma capability ensures that integrators can connect these filters into any customer-specific, single-use assembly and provide it as a sterile final assembled product
<b>PFAS Alternative</b>	Alternative to materials regulated by Per and Polyfluoroalkyl Substances (PFAS)
<b>Comprehensive validation</b>	Product has been rigorously validated to product specification and industry standards with comprehensive documentation to support compliance

## SPECIFICATIONS

		50mm Disc	3"5"10" In-line Capsule
<b>Materials</b>	Media	UPE	UPE
	Support	Polyethylene	Polyethylene
	Core, cage, end caps	Polypropylene	Polypropylene
	O-ring	Silicone	Silicone
<b>Sealing technology</b>		Thermal and ultrasonic bonding	Thermal bonding without adhesives
<b>Pore size</b>		0.22 µm	0.22 µm
<b>Filtration area</b>		19.6 cm <sup>2</sup>	3": 0.18 cm <sup>2</sup>
			5" 0.33 cm <sup>2</sup>
			10" 0.65 cm <sup>2</sup>
<b>Integrity</b>	Bubble Point	≥1.45 bar (21 psi) 60% IPA with water	≥1.45 bar (21 psi) 60% IPA with water
<b>Maximum operating conditions</b>	Maximum operating temperature	60°C (140°F)	60°C (140°F)
	Maximum operating pressure	30 psi (2.1 bar) @ 25°C (77°F)	60 psi (4.1 bar) @ 25°C (77°F)
		20 psi (1.4 bar) @ 60°C (140°F)	30 psi (2.1 bar) @ 60°C (140°F)
	Maximum differential pressure	Forward 30 psi (2.1 bar) @ 25°C (77°F)	Forward 60 psi (4.1 bar) @ 25°C (77°F)
Reverse 15 psi (1.0 bar) @ 25°C (77°F)		Reverse 30 psi (2.1 bar) @ 25°C (77°F)	
<b>Bacteria Retention*</b>	>10 <sup>7</sup> CFU/cm <sup>2</sup> B. diminuta per the ASTM F838.		
<b>Gamma stability</b>	Gamma irradiation stable up to 45 kGy		
<b>Endotoxin releasing*</b>	<0.25 EU/mL as determined by the LAL test, meeting the requirements of USP <85>		
<b>Particulates*</b>	Particulate matter release meets the requirement of USP <788>		
<b>Non-fiber releasing</b>	Manufactured with non-fiber release materials and tested according to 21 CFR 210.3 (b) (6)		
<b>Material toxicity*</b>	All components meet the requirements of the USP <87>, Biological Reactivity Test		
<b>Animal free</b>	Raw materials used to manufacture this product are not animal derived, meeting the EU directive for animal free CPMP EMA/410/01 and 21 CFR parts 189.5		
<b>Extractables*</b>	Non-Volatile Residue (NVR) tested at two successive 24-hour extractions in 50% ethanol with vibration per USP <665> & <1665>		
<b>Quality</b>	100% integrity tested, manufactured in accordance with ISO 9001 and ISO 13485 certified quality management system		

\*Test post-gamma irradiation. Refer to our validation guide for details.

## PERFORMANCE DATA

### 50 mm Disc

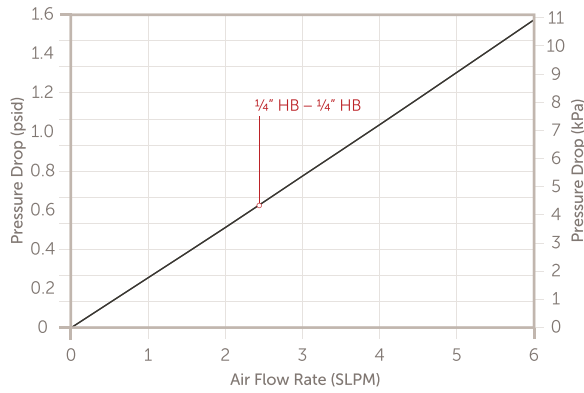

### 3-inch Capsules

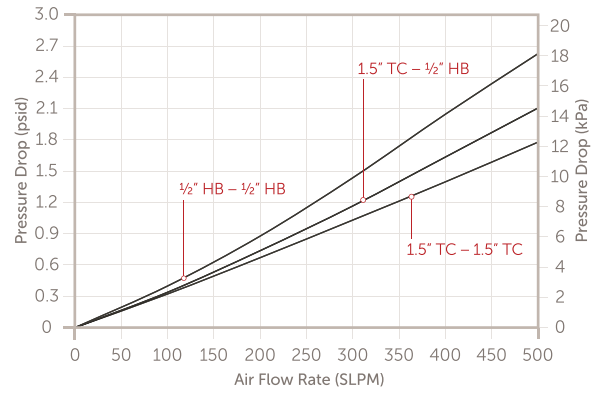

### 5-inch Capsules

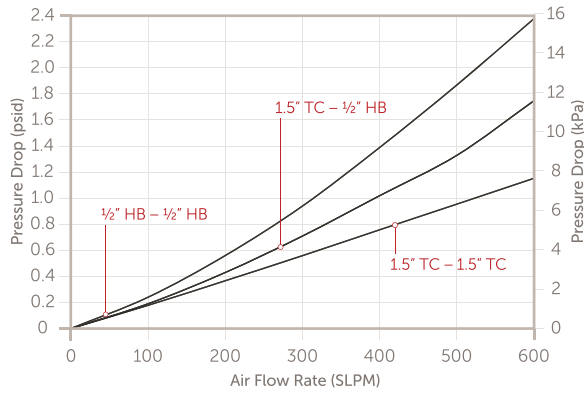

### 10-inch Capsules

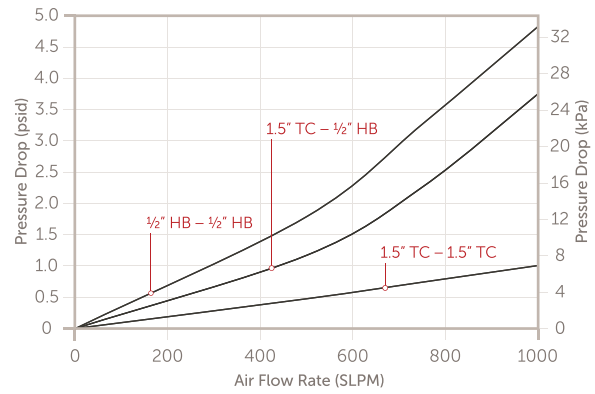

## DIMENSIONS

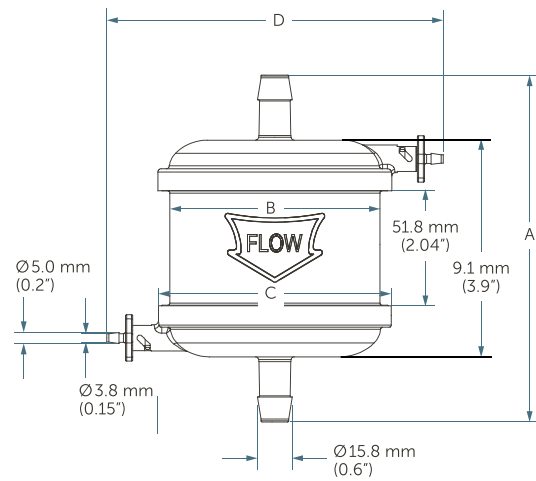
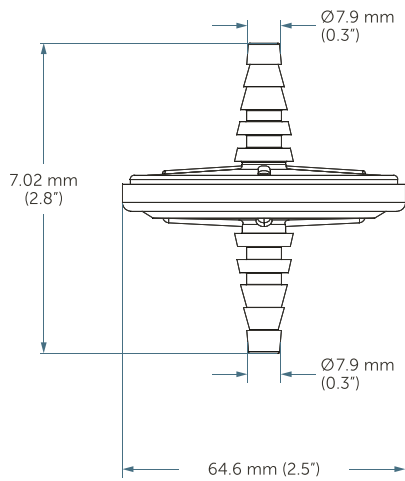

## DIMENSIONS

Size - Connections	Total Length - A	Body Diameter - B	Min Width - C	Max Width - D
3-inch TC-TC	154.5 mm (6.08")	96.0 mm (3.78")	107.0 mm (4.21")	153.0 mm (6.02")
3-inch TC-HB	156.7 mm (6.17")	96.0 mm (3.78")	107.0 mm (4.21")	153.0 mm (6.02")
3-inch HB-HB	159.7 mm (6.29")	96.0 mm (3.78")	107.0 mm (4.21")	153.0 mm (6.02")

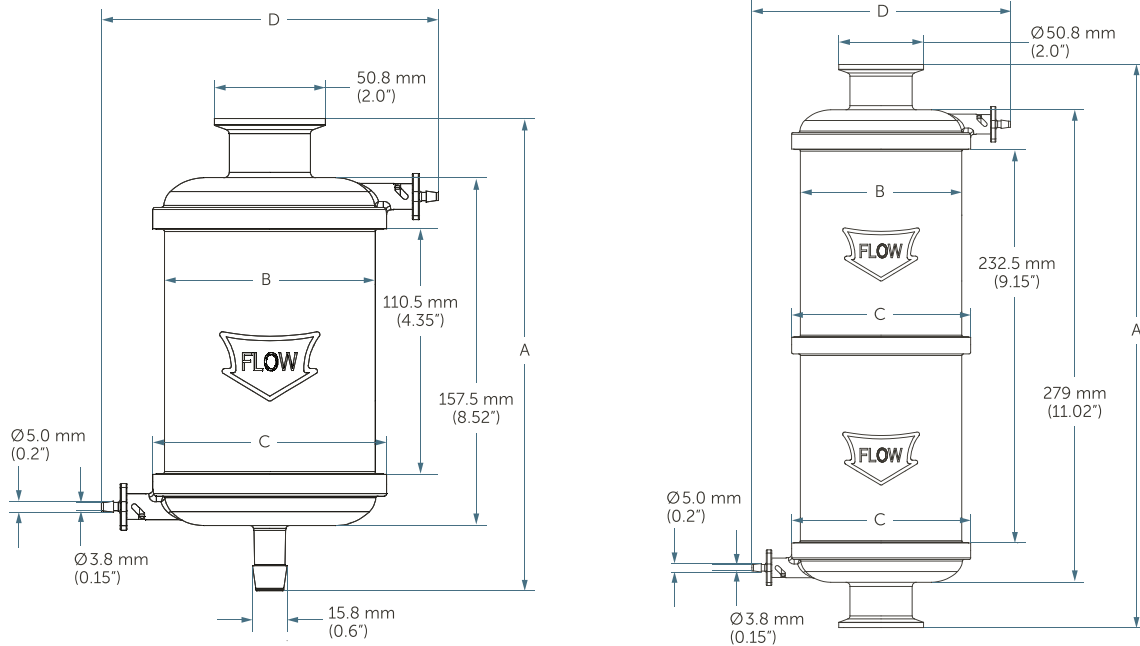

Size - Connections	Total Length - A	Body Diameter - B	Min Width - C	Max Width - D
5-inch TC-TC	213.2 mm (8.39")	96.0 mm (3.78")	107.0 mm (4.21")	153.0 mm (6.02")
5-inch TC-HB	216.5 mm (8.52")	96.0 mm (3.78")	107.0 mm (4.21")	153.0 mm (6.02")
5-inch HB-HB	219.5 mm (8.96")	96.0 mm (3.78")	107.0 mm (4.21")	153.0 mm (6.02")
10-inch TC-TC	335.5 mm (13.21")	96.0 mm (3.78")	107.0 mm (4.21")	153.0 mm (6.02")
10-inch TC-HB	339.0 mm (13.35")	96.0 mm (3.78")	107.0 mm (4.21")	153.0 mm (6.02")
10-inch HB-HB	342.0 mm (13.46")	96.0 mm (3.78")	107.0 mm (4.21")	153.0 mm (6.02")

## ORDERING INFORMATION

PART NUMBER	SIZE	INLET AND OUTLET CONNECTION	PACKAGING CONFIGURATION
PSTSUED022HS032	3" capsule	1/2" hose barb	Two per box
PSTSUED022HS051	5" capsule	1/2" hose barb	One per box
PSTSUED022HS101	10" capsule	1/2" hose barb	One per box
PSTSUED022SH0010	50 mm disc	1/4" stepped hose barb	Ten per box

## ORDERING INFORMATION

PART NUMBER	SIZE	INLET AND OUTLET CONNECTION	PACKAGING CONFIGURATION
PSTSUED022TH032	3" capsule	1.5" sanitary TC inlet and 1/2" hose barb outlet	Two per box
PSTSUED022TH051	5" capsule	1.5" sanitary TC inlet and 1/2" hose barb outlet	One per box
PSTSUED022TH101	10" capsule	1.5" sanitary TC inlet and 1/2" hose barb outlet	One per box
PSTSUED022TS032	3" capsule	1.5" sanitary TC	Two per box
PSTSUED022TS051	5" capsule	1.5" sanitary TC	One per box
PSTSUED022TS101	10" capsule	1.5" sanitary TC	One per box

Note: Pre-sterilized capsules by Gamma irradiation available, refer to part number matrix for corresponding part number or check with your Entegris specialist. Entegris and MKS have developed compatible capsule heating jackets, available directly from MKS. Check with you Entegris specialist for more information, or visit the [MKS website for Series 48 Heaters](#).

### FOR MORE INFORMATION

Please call your Regional Customer Service Center today to learn what Entegris can do for you. Visit [entegris.com](https://www.entegris.com) and select the [Contact Us](#) link to find the customer service center nearest you.

### TERMS AND CONDITIONS OF SALE

All purchases are subject to Entegris' Terms and Conditions of Sale. To view and print this information, visit [entegris.com](https://www.entegris.com) and select the [Terms & Conditions](#) link in the footer.



Corporate Headquarters  
129 Concord  
Billerica, MA 01821  
USA

Customer Service  
Tel +1 952 556 4181  
Fax +1 952 556 8022  
Toll Free 800 394 4083

Entegris®, the Entegris Rings Design®, and other product names are trademarks of Entegris, Inc. as listed on [entegris.com/trademarks](https://www.entegris.com/trademarks). All third-party product names, logos, and company names are trademarks or registered trademarks of their respective owners. Use of them does not imply any affiliation, sponsorship, or endorsement by the trademark owner.

©2024 Entegris, Inc. | All rights reserved. | Printed in the USA | 9000-13456DSA-0624