

ErgoNOW™ Connector

For Use With NOWPak® Liner-Based Bottle System

User guide



TABLE OF CONTENTS

Introduction	2	Section 5: Operating the System	14
Purpose of This User Guide	2	Removing the Tear Tab on SmartCap and IntelliCap Closures	14
To the Reader	2	Installing the Connector Onto a Bottle	15
Section 1: Safety Information	2	Changing Out an Empty Bottle.....	16
General Safety Precautions	2	Removing an ErgoNOW Connector From a Bottle	17
Section 2: System Overview	3	Section 6: System Maintenance	18
Section 3: System Components	4	Cleaning the ErgoNOW Connector.....	18
ErgoNOW™ Connectors.....	4	O-ring Handling and Replacement	18
PD-type Connectors	4	Replacing the Probe O-rings	19
Short Probe Option (PD Connectors Only).....	5	Replacing the Nozzle O-ring	19
PL-type Connectors	5	O-ring Handling Guidelines	19
SmartCap™ and IntelliCap™ Closures.....	6	Replacing the Keyed Retainer	20
SmartCap Closure	6	PL-type Connector	21
IntelliCap Closure.....	6	PD-type Connector	23
NOWPak® and PDMPak™ Bottles.....	6	Section 7: Troubleshooting	26
Section 4: Receiving and Installing the System	7	Appendix A: Required Tools and Accessories	28
Unpacking a New ErgoNOW Connector	7	Limited Warranty	30
Connecting the Gas Inlet Fitting.....	8	For More Information	30
Option A (5/32" Quick Connect with Air Fitting Kit)	8	Terms and Conditions of Sale	30
Option B (1/4" Quick Connect).....	9		
Option C (1/8" Quick Connect)	9		
Option D (1/4" Swagelok®).....	9		
Option E (1/8" FNPT Thread with Quick Connect Stem).....	9		
Option F (1/8" FNPT Thread – No Quick Connect Stem).....	9		
Option Z (No Gas Inlet Fitting – Only the Tee Fitting with PRV Installed).....	9		
Connecting the Liquid Outlet Fitting.....	10		
Pillar® Super and Super 300 Fittings.....	10		
Flowell™ or Entegris Flaretek® Fittings.....	11		
Connecting the Proximity Sensor Cable	12		

INTRODUCTION

Before reading this user guide, familiarize yourself with the following information.

PURPOSE OF THIS USER GUIDE

This guide is for use by personnel who will install, use, maintain, and repair the ErgoNOW™ bottle system keyed connector. General information and step-by-step instructions for all end user procedures and troubleshooting information are included.

TO THE READER:

The contents of this user guide have been organized into the following sections:

Section 1. Safety Information

This section provides important safety information that must be understood and followed by anyone working with an ErgoNOW connector-based system.

Section 2. System Overview

This section contains background information about the ErgoNOW connectors, their purpose and advantages.

Section 3. System Components

This section contains descriptions and illustrations of the ErgoNOW connector and other NOWPak® liner-based bottle system components.

Section 4. Receiving and Installing the System

This section contains the step-by-step procedures performed when receiving and unpacking an ErgoNOW connector, and to connect your system's gas inlet and liquid outlet lines to the ErgoNOW connector.

Section 5. Operating the System

This section contains the step-by-step procedures for installing ErgoNOW connectors to NOWPak bottles, dispensing liquid to your production tool, and for replacing an empty bottle with a fresh bottle.

Section 6. System Maintenance

This section contains the step-by-step procedures used to clean ErgoNOW connectors, to replace connector O-rings, and to replace the keyed retainer when mechanical misconnect prevention is used.

Section 7. Troubleshooting

This section contains information used to troubleshoot and solve problems in ErgoNOW connectors and NOWPak or PDMPak® bottle systems.

SECTION 1: SAFETY INFORMATION

These safety instructions must be followed whenever installing, removing, filling, operating, or working on or around the ErgoNOW connector and the NOWPak bottle system.

GENERAL SAFETY PRECAUTIONS

- Follow all appropriate chemical safety regulations.
- Wear chemical splash goggles and other appropriate Personal Protective Equipment (PPE) when handling components containing chemicals.
- Only dispense hazardous chemicals in a highly ventilated area to avoid exposure to hazardous chemical vapors.
- Observe all instructions and warnings on the ErgoNOW connector and NOWPak bottle.
- Always dispense liquids away from the operator or any other person.
- Regularly inspect the ErgoNOW connector for evidence of chemical leaks.
- If a leak is observed, stop operation and repair the leak.
- The ErgoNOW connector is supplied with a pressure relief valve to prevent overpressurization of the bottle. The standard setting for the pressure relief valve is as follows:
 - 20 psig (138 kPa) for ErgoNOW PD connector
 - 7 psig (48 kPa) for ErgoNOW PL connector

- The ErgoNOW connector must be operated with a vent valve on the pressure input line to permit venting of the pressure between the liner and the bottle.
- If dispense is interrupted or discontinued for an extended period, Entegris recommends venting the pressure between the liner and the bottle.
- The proximity sensor or RFID sensor must be connected to the production tool interlock system to ensure that the ErgoNOW connector is used only when it has been properly connected.
- Do not remove the ErgoNOW connector from the NOWPak bottle while it is pressurized. Always shut off the pressure dispense gas supply and vent the bottle before removing the connector.
- The ErgoNOW PD-type connector is designed for continuous pressure dispense applications.
- The ErgoNOW PL-type connector is designed for pump dispense and pressure assist dispense applications. When using the NOWPak bottle system with the PL-type connector in pressure assist applications, the maximum operating pressure is 5.0 psig (34 kPa), and the pressurized time must be limited to two minutes.
- Do not change O-rings to non Entegris supplied O-rings.
- Use only Entegris original parts for repair or maintenance. Safety could be compromised by using non Entegris supplied components.
- Use only Entegris recommended tools for set-up, operation, and maintenance of the ErgoNOW connector and a liner-based bottle system.

SECTION 2: SYSTEM OVERVIEW

The ErgoNOW connector provides high purity, safe delivery of liquids for chemical delivery systems. ErgoNOW connectors are available in several sizes for use with different size NOWPak bottles. Optional materials and fittings provide flexibility in using ErgoNOW connectors in a variety of applications for dispensing many different types of chemical.

Two types of ErgoNOW connector are available: PD-type connectors for pressure dispense, and PL-type connectors for pump or pressure-assist delivery systems. In both types, the bottle's liner collapses as chemical is pressed or pumped out through the ErgoNOW connector, resulting in minimal chemical waste. Sealed delivery from the bottle to the production tool ensures safe chemical delivery and prevents external contamination from entering the system at any point.

Mechanical or electronic misconnect prevention protects against installing an ErgoNOW connector onto a bottle filled with the wrong chemical. Ergonomic benefits make using the ErgoNOW connector user-friendly and safe: the self-aligning design makes it easy to install onto a NOWPak bottle; a release lever and push-off cams allow easy removal of empty bottles. Locking tabs provide positive feedback that the connector is fastened securely to the bottle, and a pneumatic cylinder (PD-type only) locks the ErgoNOW connector in place, preventing users from removing the connector when the system is under pressure.

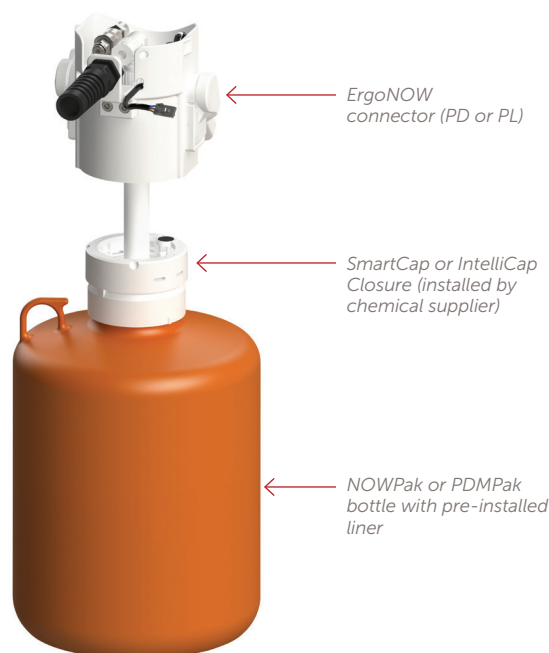

Figure 1. ErgoNOW connector with NOWPak liner-based bottle (PL default option shown).

SECTION 3: SYSTEM COMPONENTS

This section of the manual provides a description of the ErgoNOW connector and other components used in the NOWPak liner-based bottle system.

The NOWPak system consists of the following components:

- An ErgoNOW connector (PD- or PL-type)
- A SmartCap™ or IntelliCap™ closure
- A NOWPak or PDMPak bottle with pre-installed and pre-inflated liner

ERGONOW CONNECTORS

The ErgoNOW connector (Figure 2) provides a sealed pathway from the chemical-filled liner inside the bottle to the end user's production tool.

In daily use, the connector is installed onto a NOWPak or PDMPak bottle that is filled with the desired chemical and sealed with the desired closure. The pointed tip of the probe punctures the bottle closure's breakseal, and the chemical is either pressure-dispensed or pumped up through the probe to the production tool, as needed. When a bottle is empty, the connector is removed using the release lever, and then installed onto a new bottle containing the same chemical.

The ErgoNOW connector offers two types of chemical and supplier key coding to suit the end user's system. A mechanically coded feature, or an electronically coded feature using radio frequency identification (RFID) technology, mates the connector only to a matching closure to prevent costly mismatches.

A sensor cable connects the proximity or RFID sensor to the end user's production tool. The sensor signals the tool and allows chemical to be dispensed only if a bottle of the correct chemical is properly installed. A green LED on the sensor indicates that the correct bottle is installed. The sensor is not required: ErgoNOW connectors can be ordered with the sensor port plugged, and several options are available for sensor type, cable length, and connector type.

ErgoNOW connectors are available in two types – PD or PL. Select the appropriate type, depending on whether dispense is performed by pressurized gas or by pump (with pressure-assist available). Several options are available for the probe length, gas inlet fitting, liquid outlet fitting, proximity sensor type, and keyed retainer material.

The two types of ErgoNOW connector – PD and PL – look nearly identical but cannot be interchanged because they are for use in different types of dispense applications, as described below.

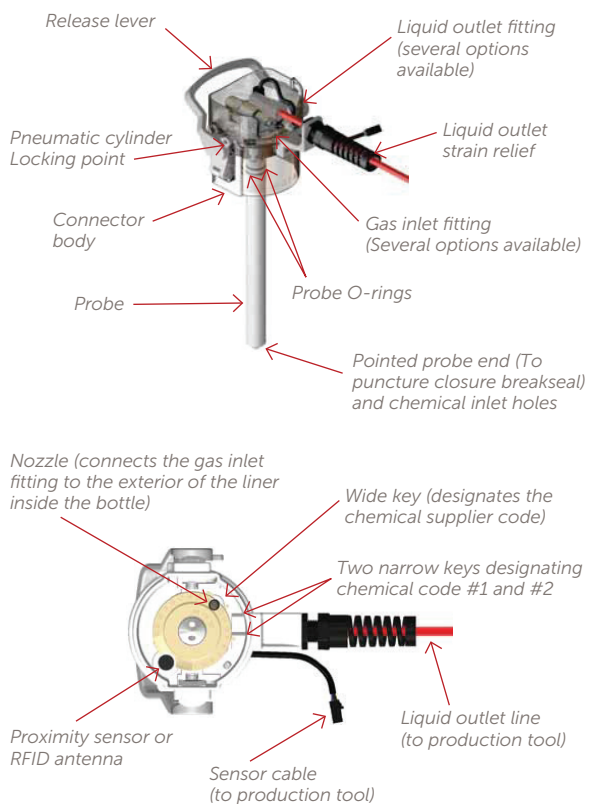

Figure 2. ErgoNOW PD-type connector (side and bottom views).

PD-type connectors

PD-type connectors are used in applications where compressed gas (usually CDA or N2) enters the ErgoNOW connector through the gas inlet fitting. The gas applies pressure to the outside of the liner inside the PDMPak bottle. The pressure compresses the liner and forces liquid up into the ErgoNOW connector and out through the liquid outlet fitting.

IMPORTANT: PD connectors must be only used with PDMPak bottles. The maximum operating pressure is 15.0 psig (103.4 kPa).

A pneumatically operated cylinder protects against users removing the dispense connector while the bottle is under pressure. When pressure to the bottle rises above 5 psig (34 kPa), the cylinder extends, locking the release lever in the “down” position. The handle cannot be raised until pressure is vented and the cylinder is retracted.

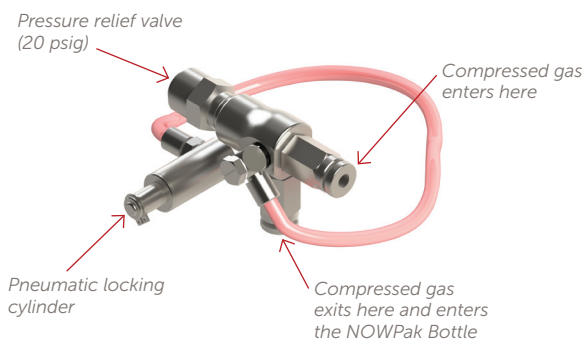

Figure 3. Gas inlet fitting for PD-type ErgoNOW connector.

Short Probe Option (PD-type Connectors Only)

The ErgoNOW connector can be ordered with a “short probe” option (Figure 4). This option is for pressure dispense (PD) applications only – the short probe is not suitable for pump dispense applications.

The purpose of the short probe is to draw chemical from the top of the bottle, rather from the bottom. This removes all air (bubble/headspace/dissolved gas) out of the bag at the start of the dispense cycle.

The short probe prevents bubbles from coming out into the fluid outlet line and maximizes chemical usage from each bottle. Using the short probe also minimizes the vertical clearance needed to remove the ErgoNOW connector from a bottle.

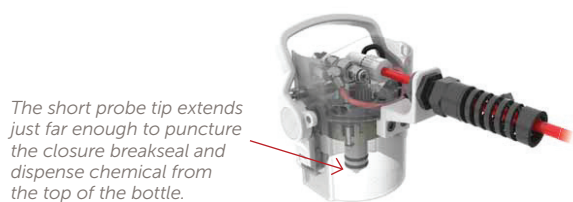

Figure 4. ErgoNOW connector with short probe option.

PL-type Connectors

PL-type connectors are used in applications where a pump is used to draw liquid out of the bottle through the liquid outlet fitting. The gas inlet fitting (Figure 5) allows ambient air (or clean gas provided by the end user) to flow freely into the NOWPak bottle, to the outside of the liner. As chemical is pumped from the bottle, incoming gas causes the liner to collapse and results in maximum usage of chemical from every bottle.

The pressure assist feature permits the user to apply low pressure gas to the gas inlet fitting at the start of each dispense cycle. This helps start the flow of dense or viscous fluids where pumping alone may not be sufficient. Once the flow is underway, gas pressure is removed and the pump maintains the desired flow. It is the customer’s responsibility to provide proper valves and controls to turn the gas pressure on and off, and to switch over from pressure-assist to pump dispense when chemical flow is underway.

⚠ WARNING: When using pressure assist with a PL-type connector and bottle, a maximum operating pressure of 5 psig (34 kPa) may be applied. Do not apply pressure for more than 2 minutes. Failure to follow this warning could result in ruptured containers and chemical spills.

The gas inlet fitting (Figure 5) on PL-type connectors looks substantially different than those on PD-type connectors – mainly because the PL-type connectors do not have the pneumatic locking cylinder feature.

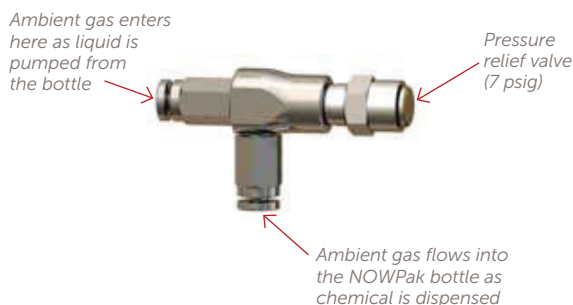

Figure 5. Gas inlet fitting for PL-type ErgoNOW connector.

SMARTCAP AND INTELLICAP CLOSURES

Both ErgoNOW connector types (PD and PL) may be installed onto a bottle that has either a SmartCap or an IntelliCap closure installed. The chemical supplier seals each bottle with the desired closure after filling the bottle with the specified chemical.

Each closure type has a breakseal, which is ruptured by the probe of the ErgoNOW connector when it is installed onto the NOWPak or PDMPak bottle. To ensure that the integrity of the key code protection is maintained at all times, closures are discarded with the liner when each bottle is emptied.

Both closures are designed with misconnect protection, guarding against the risk of contamination due to a chemical bottle misconnection:

- SmartCap closures are mechanically key coded. Each SmartCap has notches that will mate only to an ErgoNOW connector with matching notches cut into the keyed retainer. Only a matched code set will allow chemical dispense.
- IntelliCap closures contain an RFID tag which provides an electronic key code designed to mate only to a matched ErgoNOW connector. The connector aligns with an RFID tag in the closure to provide visual and electronic indication that the connector and the bottle's contents are a match.

SmartCap Closure

The SmartCap closure (Figure 6) is a mechanically-coded cap designed to mate only to a matched ErgoNOW connector. Key coding is accomplished by three coded notches cut into the SmartCap, and three corresponding notches cut into the keyed retainer inside the ErgoNOW connector. An ErgoNOW connector can only be installed onto a SmartCap closure if all three of the notches match.

In the example shown below, the SmartCap key code illustrated is 23-21-22, the Entegris default key code. Each customer has their own unique key code designated by the notched numbers on the closure top. The key code consists of one wide notch (home position) and two narrow notches (chemical) that are located on the inside surface of the closure top. The wide notch identifies the customer, and the two narrow notches identify the customer's chemical. The round-shaped notches on the outside surface of the closure top are torque tool grooves used in conjunction with a torque tool to tighten the closure onto the bottle.

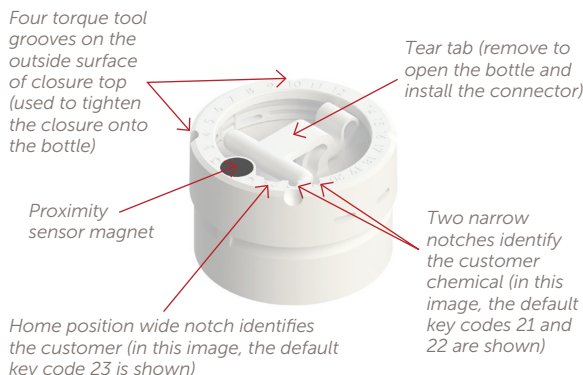

Figure 6. SmartCap closure (with key code number 23-21-22).

Intellicap Closure

The Intellicap closure (Figure 7) is designed for use with the NOWTrak® RFID System. The RFID tag contains a unique code which is read by the RFID antenna in the ErgoNOW connector. The code must match the chemical ID in order for the production tool to use the bottle.

Any ErgoNOW connector will fit onto any IntelliCap, but unless the electronic key codes match, as detected by the NOWTrak system, chemical will not be dispensed. It is the end user's responsibility to ensure the correct key codes are used and ordered from the chemical supplier.

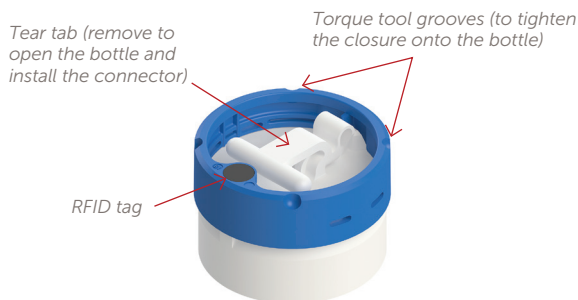

Figure 7. IntelliCap closure.

NOWPAK AND PDMPAK BOTTLES

NOWPak and PDMPak bottles (Figure 8) are high-density polyethylene bottles with a UV block additive (amber bottles only) and are available in a variety of sizes. The high-density polyethylene (HDPE) bottle resists breakage even if dropped or struck.

The chemical supplier fills either the NOWPak or PDMPak with the desired chemistry and seals it with a coded SmartCap or Intellicap closure, as ordered by the customer.

⚠ WARNING: Maximum operating pressure is 15.0 psig (103.4 kPa) for a PDMPak bottle, and 5 psig (34 kPa) for a maximum of two minutes for a NOWPak bottle. If you exceed maximum pressure, bottle rupture and chemical spill may result.

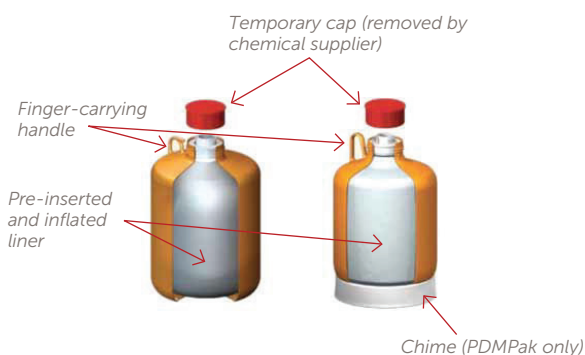

Figure 8. NOWPak and PDMPak bottle (cutaways).

NOWPak and PDMPak bottles are available, as shown above. The best bottle type for a given application depends on the required size and whether chemical will be dispensed under pressure or with a pump:

- The NOWPak bottle (above) is used for pump or pressure assist dispense and is rated for up to 5 psig (34 kPa) for a maximum duration of two minutes.
- The PDMPak bottle (above) is used for pressure dispense up to 15.0 psig (103.4 kPa). PDMPak bottles are recognizable by the chime used to support the bottle.

Both bottle types are available in several sizes.

IMPORTANT: Each bottle size corresponds to a specific probe length on the ErgoNOW connector. It is the customer's responsibility to ensure that the bottle size matches the probe length when installing an ErgoNOW connector onto a bottle.

NOWPak and PDMPak T420 and T650 liners are manufactured and pre-cleaned in a Class 5 Cleanroom as per International Standard ISO 14644-1.* Cleanrooms and associated controlled environments – Part 1: Classification of air cleanliness.

*ISO standard certification is kept up to date as necessary to remain current and effective to be able to demonstrate compliance with up-to-date ISO requirements.

NOWPak T420 and T650 bottle system assemblies and replacement liners are certified for liquid particles and trace metals. NOWPak 4-liter T420 bottle system assemblies and replacement liners are also certified for total siloxanes and volatile organic compounds. A Certificate of Analysis (CoA) stating lot-specific data is available for each shipment of product. More detailed information regarding product specifications can be found on the product data sheets available on the Entegris web site.

SECTION 4: RECEIVING AND INSTALLING THE SYSTEM

Use the following procedures to unpack a new ErgoNOW connector, connect the gas inlet and liquid outlet lines, and prepare the system for use.

UNPACKING A NEW ERGO NOW CONNECTOR

Use this procedure to unpack an ErgoNOW connector from the shipping carton.

Follow these steps:

1. Examine the shipping container for any damage that may have occurred during transit. Contact your Entegris Sales Account Manager or customer service representative if any damage is observed.
2. Remove the ErgoNOW connector from the shipping container. Do not remove it from the double bags.

NOTE: The ErgoNOW connector is double bagged. The inner shipping bag should only be opened in the cleanroom.

3. While still in the double bags, examine the ErgoNOW connector for any damage. Contact your Entegris Sales Account Manager or customer service representative if any damage is observed.

IMPORTANT: Handle the ErgoNOW connector by the connector body only, not by the PTFE probe. The probe has been pre-cleaned and handling it can result in damage and contamination.
4. In a suitable staging area, remove the ErgoNOW connector from the outer shipping bag and transport it to the cleanroom.
5. Verify that the key code on the ErgoNOW connector matches the chemical used on the production tool where the connector will be installed.

6. If they are not identical, use a connector that matches the key code, or check to verify the correct chemical is specified on the production tool.
7. Remove the ErgoNOW connector from the inner shipping bag inside the cleanroom. Do not handle the probe.
8. Inspect the two probe O-rings to verify they are seated in the O-ring grooves on the probe.
9. Connect the tubing from the production tool to the ErgoNOW connector. See "Connecting the Gas Inlet Fitting" below and "Connecting the Liquid Outlet Fitting" on page 10 for installation procedures.
10. Install the ErgoNOW connector onto a NOWPak bottle for use with your production tool. See "Installing the connector onto a bottle" on page 15.

CONNECTING THE GAS INLET FITTING

Tubing must be connected to the gas inlet fitting (Figure 9) on the ErgoNOW connector for either type of application, as follows:

- For pressure dispense or pressure assist dispense installations, an external source of pressurized N₂ or CDA is used to compress the liner and dispense chemical from the bottle.
- For pump dispense applications, the gas inlet fitting is used to allow air (or customer-supplied gas) to flow into the space between the liner and the bottle as chemical is pumped from the bottle.

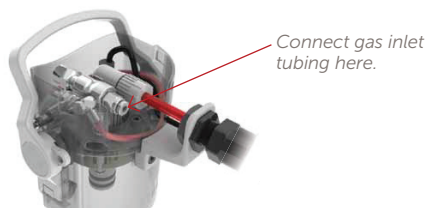

Figure 9. Gas inlet fitting connection.

The tubing size, connection method, and the hardware needed depends on the gas inlet fitting option ordered with the ErgoNOW connector. A variety of options are available: A, B, C, D, E, F, and Z, as described below.

Additional options may be available. Contact your Entegris Sales Account Manager for more information.

Option A (5/32" Quick Connect with Gas Fitting Kit)

Option A is a 5/32" quick connect fitting that comes with a gas fitting kit to provide the end user with several alternatives.

The gas fitting kit (shown in Figure 10) includes one reducer, one bulkhead adaptor fitting, and one 1/8" quick connect fitting.

Use one of the following methods to connect 5/32" tubing or 1/8" tubing to the gas inlet fitting:

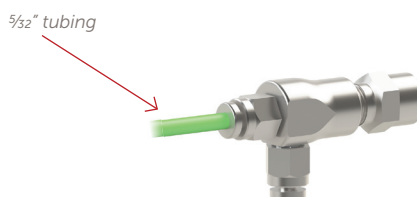

Insert 5/32" tubing directly into the tee fitting.

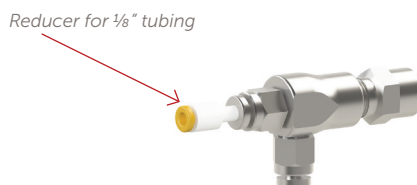

Insert the reducer into the tee fitting. Then insert 1/8" tubing into the reducer.

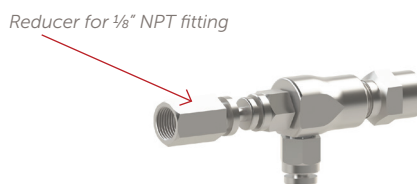

Insert the bulkhead adapter fitting into the tee fitting for a 1/8" NPT connection.

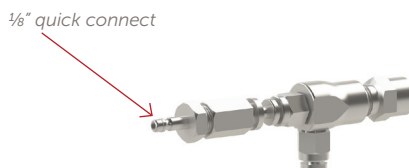

Screw the 1/8" quick connect into the bulkhead adapter fitting.

Figure 10. Connecting the gas inlet tubing using Option A with gas fitting kit.

IMPORTANT: It is the customer's responsibility to provide appropriate gas inlet tubing, and to install and operate the controls needed to provide inlet gas into the ErgoNOW connector.

Option B (1/4" Quick Connect)

Option B consists of a 1/4" quick connect fitting. Insert 1/4" gas tubing directly into the tee fitting on top of the ErgoNOW connector (see Figure 11).

NOTE: Gas inlet fitting Option B does not come with a gas fitting kit.

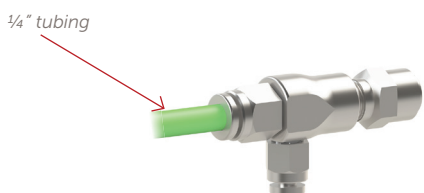

Figure 11. Connecting 1/4" gas inlet tubing using Option B

Option C (1/8" Quick Connect)

Option C consists of a 1/8" quick connect fitting. Insert 1/8" gas tubing directly into the tee fitting on top of the ErgoNOW connector (see Figure 12).

NOTE: Gas inlet fitting Option C does not come with a gas fitting kit.

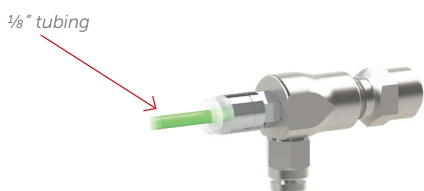

Figure 12. Connecting 1/8" gas inlet tubing using Option C

Option D (1/4" Tube, Swagelok®)

Option D consists of a 1/4" Swagelok fitting. Insert 1/4" tubing directly into the tee fitting on top of the ErgoNOW connector. (see Figure 13).

NOTE: Gas inlet fitting Option D does not come with a gas fitting kit.

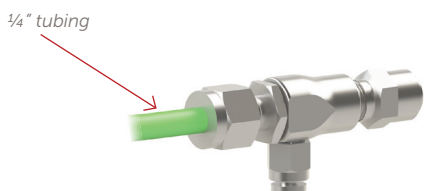

Figure 13. Connecting 1/4" gas inlet tubing using Option D.

Option E (1/8" FNPT Thread with Quick Connect Stem)

Option E consists of a 1/8" FNPT thread with Quick Connect stem. Insert 1/8" tubing directly into the tee fitting on top of the ErgoNOW connector. (see Figure 14).

NOTE: Gas inlet fitting Option E does not come with a gas fitting kit.

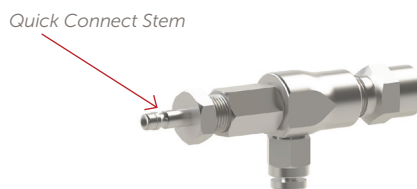

Figure 14. Connecting 1/8" FNPT thread with Quick Connect Stem using Option E.

Option F (1/8" FNPT Thread – No Quick Connect Stem)

Option F consists of a 1/8" FNPT thread. There is no Quick Connect stem. (see Figure 15).

NOTE: Gas inlet fitting Option E does not come with a gas fitting kit.

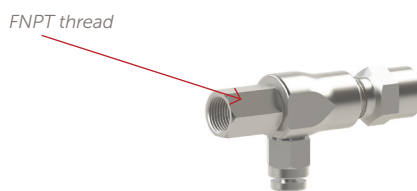

Figure 15. Connecting 1/8" FNPT thread using Option F.

Option Z (No Gas Inlet Fitting – Only the Tee Fitting with PRV Installed)



Figure 16. No gas inlet fitting – Option Z.

CONNECTING THE LIQUID OUTLET FITTING

As chemical is dispensed from the bottle, it flows up through the probe into the ErgoNOW connector and out through the liquid outlet fitting. Tubing must be connected to the liquid outlet fitting (Figure 17) to carry the chemical to the production tool.

The tubing size, connection method, and the hardware needed depends on the liquid outlet fitting option ordered with the ErgoNOW connector. Options include Pillar® Super or Super 300 fittings, Flowell™ 60 Series fittings, and Entegris Flaretek® fittings, among others.

Contact your Entegris Sales Account Manager for specific options.

IMPORTANT: Entegris strongly recommends use of the ErgoNOW connector strain relief as it prevents kinks in the chemical line by providing extra mechanical strength to the connector's liquid outlet tubing.

The strain relief adaptor and bracket are included with each ErgoNOW connector, but are not installed. The bracket must be installed onto the connector by the end user.

NOTE: When attaching the strain relief bracket, torque only to 5 in•lbf. Over tightening the strain relief bracket could result in stripping of the screw threads or damage to the connector body.

Connect liquid outlet tubing here

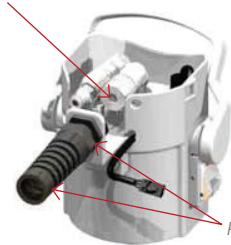

Pass the tubing through the strain relief and connect the bracket to the ErgoNOW connector body

Figure 17. Liquid outlet fitting connection.

NOTE: For detailed instructions on connecting different types of fittings, go to the fitting manufacturer's web site for current information.

Pillar Super and Super 300 Fittings

Use this procedure to connect the tubing from the production tool to the liquid outlet fitting on the ErgoNOW connector when a Pillar Super or Super 300 (S 300) fitting is used.

The Pillar fittings require the use of the provided sleeve (shown in purple in Figure 18) to form the seal. The sleeve is inserted into the tube using either a hot or cold insertion tool, available from Pillar.

Tools required (see "Required Tools and Accessories" on page 28):

- Tube cutter
- Sleeve insertion tool (from Pillar)
- 5/32" hex wrench

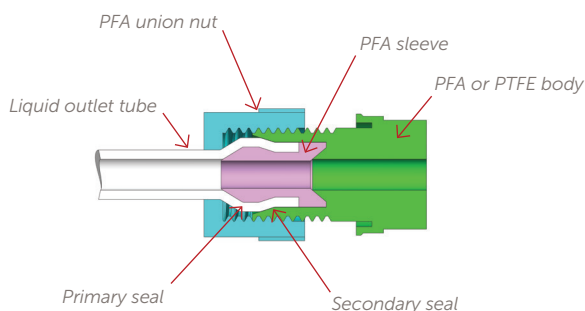

Figure 18. Cross-section of Pillar Super 300 fitting.

NOTE: For detailed instructions on installing Pillar Super or Super 300 fittings, download a copy of their instruction manual from the manufacturer's web site.

Follow these steps:

1. Cut tube end squarely using a tube cutter.
2. Unscrew the ErgoNOW connector strain relief adapter from its bracket.



Figure 19. Strain relief adapter and bracket.

3. Insert the tube through the strain relief adapter and bracket.
4. Slide the nut from the Pillar fitting over the end of the tube.



Figure 20. Sliding the nut over the tube.

5. Insert the sleeve into the end of the tube using the appropriate hot or cold sleeve insertion tool from Pillar.

If using standard wall tubing instead of thin wall tubing, replace the insert sleeve in the Pillar fitting with the sleeve packaged separately with the ErgoNOW connector.



Figure 21. Insert sleeve into the tube.

6. Tighten the nut until the gap gauge is between the upper and lower gap limits, per the Pillar instruction manual.

7. Slide the strain relief bracket up to the ErgoNOW connector body. Attach the bracket to the connector body using two 10-32 x 0.5" socket head cap screws and a 5/32" hex wrench.

NOTE: When attaching the strain relief bracket, torque only to 5 in•lbf. Over tightening the strain relief bracket could result in stripping of the screw threads or damage to the connector body.

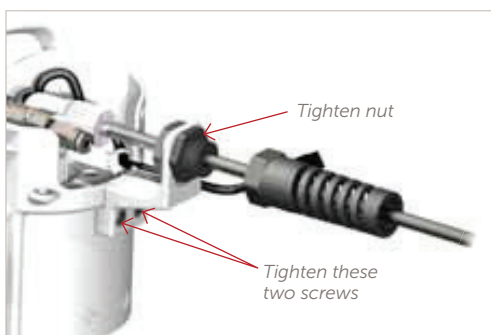

Figure 22. Attaching the strain relief bracket.

8. Re-attach the strain relief adapter by screwing it onto its base. The liquid outlet line is now connected to the ErgoNOW connector.



Figure 23. Tightening the strain relief.

Flowell or Entegris Style Fittings

Use this general procedure for installing the liquid outlet tubing to an ErgoNOW connector using a Flowell, Entegris, or similar type of fitting where the end of the tube must be flared before connecting to the liquid outlet fitting.

Depending on the fitting type, hot or cold flaring may be required. See the fitting manufacturer's instructions for detailed procedures on flaring the tubing.

Tools required (not supplied by Entegris):

- Tube cutter
- Hot or cold flare tool
- Flowell inspection gauge (Flowell only)
- 5/32" hex wrench
- 17 mm wrench (Flowell only)

Follow these steps:

1. Cut the tube end squarely using a tube cutter.
2. Unscrew the ErgoNOW connector's strain relief adapter from its bracket.



Figure 24. Strain relief adapter and bracket.

3. Insert the tube through the strain relief and bracket.

- Slide the nut from the fitting over the end of the tube.

NOTE: Be sure to insert the tubing through the strain relief adapter, bracket, and fitting nut before flaring the tube.



Figure 25. Sliding the nut over the tube.

- Flare the end of the tube per the fitting manufacturer's instructions. The tube may need to be heated, or may be able to be flared at room temperature. Download instructions or manuals from the Flowell or Entegris websites, as needed.

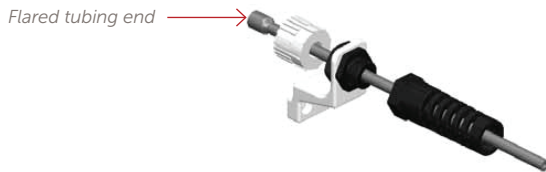

Figure 26. Flared tube end.

- Push the flared tubing end onto the fitting on the ErgoNOW connector, per the fitting manufacturer's instructions.
- Tighten the nut onto the ErgoNOW connector fitting per the fitting manufacturer's instructions. Hand tighten or torque the nut as instructed by the manufacturer.
- Slide the strain relief bracket up to the connector body. Attach the bracket to the connector body using two 10-32 x 0.5" socket head cap screws and a 5/32" hex wrench.

NOTE: When attaching the strain relief bracket, torque only to 5 in•lb. Over tightening the strain relief bracket could result in stripping of the screw threads or damage to the connector body.

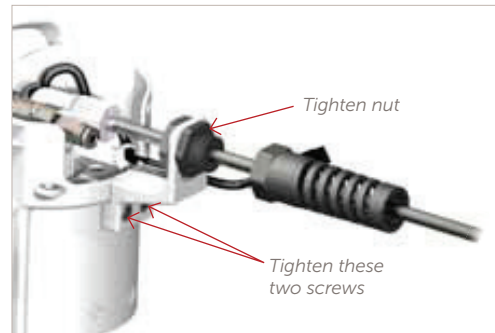

Figure 27. Attaching the strain relief bracket.

- Reattach the strain relief adapter by screwing it onto its base and tightening. The liquid outlet line is now connected to the ErgoNOW connector.



Figure 28. Tightening the strain relief adapter.

CONNECTING THE PROXIMITY SENSOR CABLE

A proximity sensor cable (Figure 29) carries signals back and forth between the ErgoNOW connector sensor and the end user's production tool.

When mechanical misconnect prevention is used, the proximity sensor in the ErgoNOW connector sends a signal when the sensor is aligned with the magnet in a NOWPak bottle sealed with a SmartCap closure. When the ErgoNOW connector senses that a bottle is installed (this requires that the key-code notches match), the green LED glows and it signals the production tool that chemical can be dispensed from the bottle.

When electronic misconnect prevention is used, the RFID antenna in the ErgoNOW connector senses whether an RFID tag on a connected bottle's IntelliCap closure is in position. Chemical can only be dispensed if the coding in the closure's RFID tag matches the coding expected by the production tool.

Several options are available for sensor type, cable length, and connector type, including open ended with no connector, as shown in Figure 29. See the proximity sensor specifications table below. Install the connector at one end of the cable to the sensor on the ErgoNOW connector. Install the connector (or the loose wiring) at the other end of the cable to your production tool.

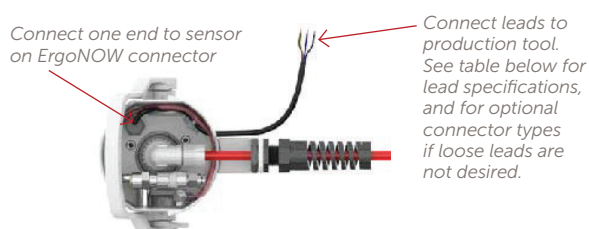

Figure 29. Proximity sensor cable with loose leads.

The proximity sensor specifications are listed in the table below. Contact your Entegris Sales Account manager for sensor interface hook-up instructions.

	OUTPUT TYPE	
	NPN	PNP
Operation mode	Normally open	Normally open
Supply voltage	12 – 24 VDC (voltage limit including ripple 10 – 38 VDC)	12 – 24 VDC (voltage limit including ripple 10 – 38 VDC)
Maximum load current	200 mA	200 mA
Current consumption (no load)	10 mA (3 mA typical)	10 mA (3 mA typical)
Wire gauge	24 AWG	24 AWG
PVC cable configuration	Brown = positive supply voltage Blue = negative supply voltage Black = signal lead	Brown = positive supply voltage Blue = negative supply voltage Black = signal lead
Sensor connector options	<ul style="list-style-type: none"> • Tyco Electronics (formally AMP) connector part number 4-14735623 (connector) and 5-1473571-3 (junction box) • Molex connector part number 50-57-9403 • No connector 	<ul style="list-style-type: none"> • No connector
CE compliant	Yes	Yes

NOTE: For NOWTrak users, for information regarding the RFID sensor, please contact your Entegris sales account manager or customer service representative for assistance.

NOTE: Sensor must be kept free and clean of photoresist or other chemistries for proper operation.

SECTION 5: OPERATING THE SYSTEM

Normal operation of the ErgoNOW connector includes installing the connector onto a NOWPak or PDMPak bottle and changing out the bottle when empty. Chemical dispense is performed as directed by the end user's production tool.

REMOVING THE TEAR TAB ON SMARTCAP AND INTELICAP CLOSURES

1. Position the bottle on a level, stable surface.
2. Then rotate the NOWPak or PDMPak bottle so that the proximity sensor magnet or RFID tag is closest to your body.

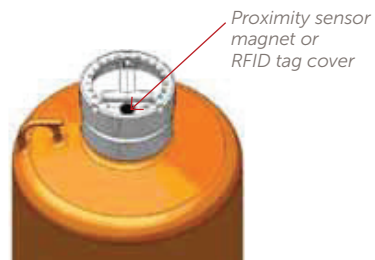

If using the tear tab removal tool:

3. Place the forks of the tool under the tear tab handle with the body of the tool resting on the edge of the closure.
4. Push down on the tool handle until the tear tab is separated from the closure.



If removing the tear tab by hand:

3. Place your index and middle fingers under the tear tab handle.
4. Lift up slightly, then pull up and toward you.

IMPORTANT: Do not repeatedly flex the tear tab up and down as it could break, preventing the tear tab port from opening.



5. With the tear tab removed, the closure's gas inlet and liquid outlet ports are exposed.

The NOWPak or PDMPak bottle is now ready to be connected to an ErgoNOW connector.

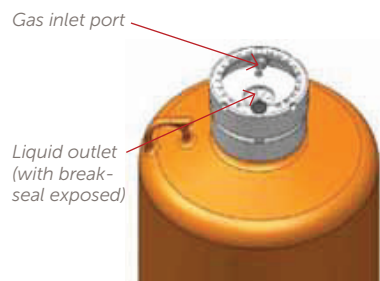

INSTALLING THE CONNECTOR ONTO A BOTTLE

Use this procedure to install an ErgoNOW connector onto a bottle.

Tools required (see “Required Tools and Accessories” on page 28):

- Tear tab removal tool part number NA-47 (Delrin) or NA-47-SS (stainless steel).

⚠ WARNING: Follow all chemical safety procedures and wear chemical splash goggles and other appropriate personal protective equipment when handling components containing chemicals.

⚠ WARNING: Do not use the ErgoNOW connector or the connector’s release lever to lift or carry a bottle. This will cause the bottle to release from the connector and could result in a chemical spill.

Follow these steps:

1. Inspect the spring loading on the release lever of the ErgoNOW connector:
 - a. Raise the lever above the top of the connector. The two tabs (clips) beneath the ends of the release lever should extend out from the connector body.
 - b. When released, the lever should return to the down position.
2. Remove the tear tab from the closure. See “Removing the Tear Tab on SmartCap and IntelliCap Closures” on page 14.

3. Rotate the bottle or ErgoNOW connector to align the proximity sensor magnet or RFID chip on the closure with the arrow on the outside of the ErgoNOW connector body.

NOTE: The arrow on the connector body must be aligned with the black dot on the bottle closure before lowering the connector onto the closure and bottle. Failure to properly align the connector to the closure could result in damage to the nozzle or key code notches.

4. Install the ErgoNOW connector onto the bottle (see Figure 30):
 - a. Let the release lever return to the “down” position.
 - b. Puncture the breakseal with the pointed end of the connector probe using a 90° angle, lowering the connector and probe into the bottle with a straight-down vertical motion.
 - c. Place both hands on top of the ErgoNOW connector and push down until it mates with the closure. Engagement is confirmed by an audible click as the connector locking tabs snap into place.
 - d. If the ErgoNOW connector does not engage, rotate it slightly for the self-aligning feature to work.
5. Verify that the green LED on the proximity sensor is illuminated. This signifies that the bottle is properly installed and the correct chemical connection has been made.

NOTE: Entegris recommends that the user check for leaks at the liquid outlet fitting, the ErgoNOW connector body, and the closure and bottle interface, using customer-approved procedures. See Section 7. Troubleshooting for additional information and leak checking procedures.

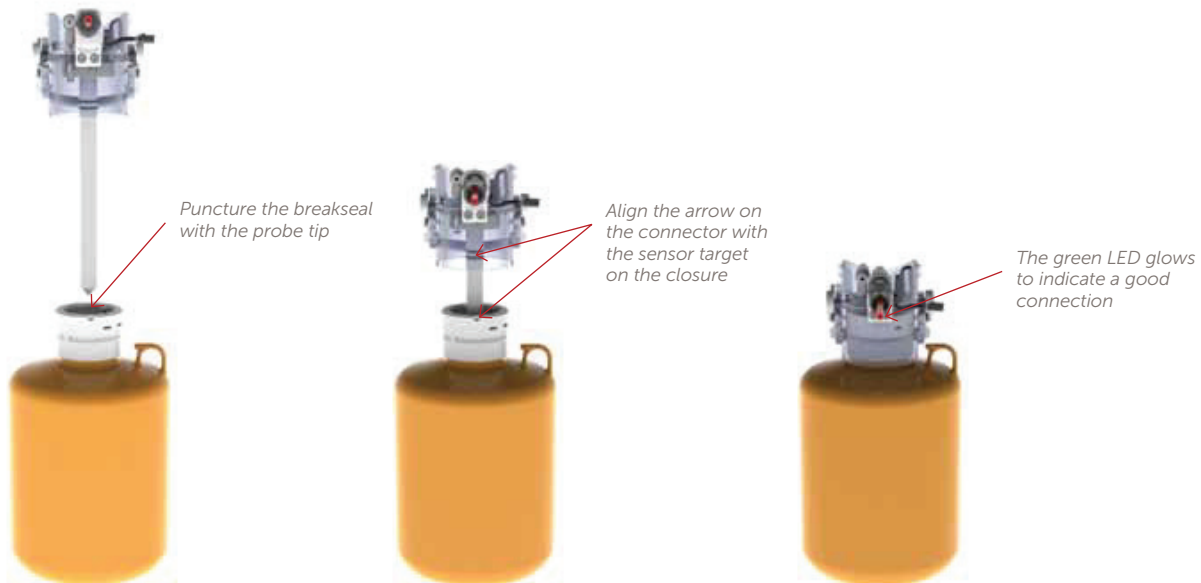

Figure 30. Installing the ErgoNOW connector onto a bottle.

CHANGING OUT AN EMPTY BOTTLE

Use this procedure to remove the ErgoNOW connector from an empty bottle and reinstall it onto a full bottle of the same chemical.

Tools required (see “Required Tools and Accessories” on page 28):

- Tear tab removal tool, part number NA-47 (Delrin) or NA-47-SS (stainless steel)
1. Vent the pressure dispense gas system. Be certain to relieve the pressure between the bottle and liner.
 2. Verify the chemical label on the new bottle is identical to that of the old bottle. If the chemical labels are not identical, do not proceed.

NOTE: Dispense gas to the tool reservoir may be used to continue delivery from the reservoir during bottle change out. This may be done automatically by the production tool.
 3. Remove the closure tear tab from the new NOWPak bottle. See the “Removing the Tear Tab On SmartCap and IntelliCap Closures” section on page 14.
 4. Carefully remove the ErgoNOW connector from the empty bottle. See “Removing an ErgoNOW connector from a bottle” on page 17 for instructions.

⚠ WARNING: When removing the ErgoNOW connector from the NOWPak bottle, some chemical may remain on the probe. Follow all chemical safety procedures and wear chemical splash goggles and other appropriate personal protective equipment.

5. Inspect the two O-rings on the connector probe to verify they are seated in the O-ring grooves and are not damaged. Replace damaged or worn O-rings. See “O-ring Handling and Replacement” on page 18 for probe O-ring replacement procedure.
6. Insert the ErgoNOW connector into the new bottle. See “Installing the connector onto a bottle” on page 15 for instructions.
7. Re-pressurize the system and check for leaks. Prime the production tool to remove air from the liquid outlet line between the ErgoNOW connector and your production tool reservoir, if required.
8. Prepare the empty bottle for recycling or disposal. Follow your company’s standard operating procedures and local regulations.

NOTE: Entegris offers a plug for sealing up the SmartCap or IntelliCap breakseal opening, part number NA-65-100, and a liner fitment plug, part number NA-07-100. These parts help contain chemical in preparation for disposal.

REMOVING AN ERGONOW CONNECTOR FROM A BOTTLE

Use this procedure to remove the ErgoNOW connector from an empty bottle and reinstall it onto a full bottle of the same chemical.

⚠ WARNING: Be sure to follow this procedure correctly and carefully. If performed improperly, lifting the ErgoNOW connector from the bottle can cause chemical to fly off the probe, hitting you or other people. Follow all chemical safety procedures and wear chemical splash goggles and other appropriate personal protective equipment when performing this procedure.

1. Pull the ergonomic release lever into a vertical position while holding the bottle in place with the other hand. Do not lift the ErgoNOW connector away from the bottle yet (see Figure 31).
The push-off cams in the ErgoNOW connector break the seal between the bottle and the connector. You should feel a “click” when the ErgoNOW connector is disconnected.
2. Allow the lever to return to the original position.
3. Remove the connector by grasping the connector body (not the handle) and lifting it off while securing the bottle with the other hand.

IMPORTANT: You must remember that the release lever on the ErgoNOW connector is to be used only to release the connector from the bottle. The lever is not a handle and must not be used to lift the ErgoNOW connector from the bottle.

STOP! IMPROPER PROCEDURE SHOWN BELOW

Do not remove the connector body while holding the release lever. This can result in uncontrolled chemical release from residual flicking off the probe in the direction of the operator(s) and surrounding environment.

Unfortunately, this person is using the release handle to lift the ErgoNOW connector from the bottle.

The spring-loaded handle causes the ErgoNOW connector to suddenly and forcefully flip 90°. Chemical on the probe may fly into the air and create a hazard.

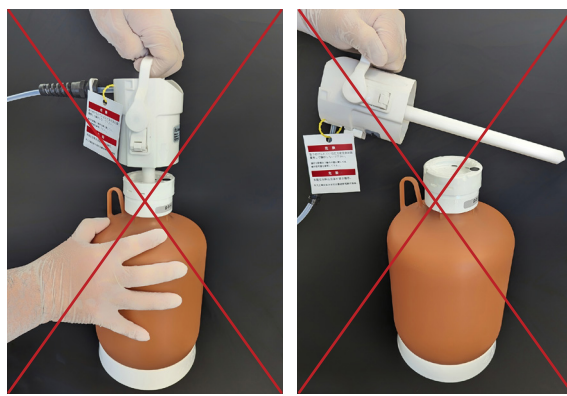

Figure 32. Wrong! Never use release lever to remove the connector.

Lift the release lever only until the side tabs pop out and the ErgoNOW connector releases from the bottle.

Lower the release lever back down. Be careful – the lever is spring-loaded and can catch your finger.

Grip the ErgoNOW connector body and lift from the bottle.

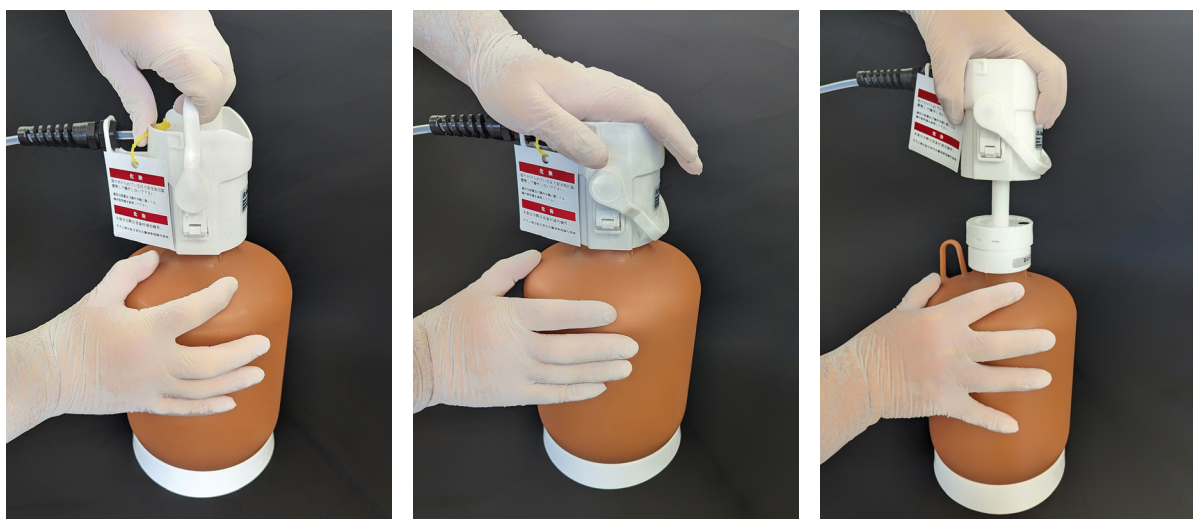

Figure 31. Correct procedure for removing the ErgoNOW connector.

SECTION 6: SYSTEM MAINTENANCE

The maintenance procedures in this section refer to the ErgoNOW connector. There are no maintenance items for the SmartCap or IntelliCap closure or for the NOWPak or PDMPak bottles.

⚠ WARNING: Perform ErgoNOW connector maintenance only after venting the pressure between the liner and the bottle, closing the pressure dispense gas inlet valve, and liquid outlet valve, and removing the ErgoNOW connector from the bottle. Attempting maintenance while the connector is connected to a pressurized bottle may result in injury to the operator and/or damage to the ErgoNOW connector.

CLEANING THE ERGONOW CONNECTOR

Periodic cleaning of the wetted components is recommended. Ensure that any cleaning solvents used are compatible with the PVC cabling of the proximity or RFID sensor. The surface of the proximity sensor should also be kept clean for proper operation. A clean swab can be used to clean the proximity or RFID sensor while still assembled on the ErgoNOW connector.

O-RING HANDLING AND REPLACEMENT

The frequency of O-ring replacement depends on the connector length of service, frequency of bottle changes, and chemical characteristics. Inspect the O-rings every time the ErgoNOW connector is removed from a bottle. If the O-rings are worn or damaged, they should be replaced. The Entegris-recommended mean time between replacement (MTBR*) is 6 months for the probe O-rings, and 12 months for the nozzle O-ring.

⚠ WARNING: When removing the ErgoNOW connector from the NOWPak bottle, some chemical may remain on the probe. Follow all chemical safety procedures and wear chemical splash goggles and other appropriate personal protective equipment.

Tools required (see "Required Tools and Accessories" on page 28):

- O-ring pick part number NA-27

Items needed:

- New probe O-rings, choice of:
 - Chemraz, part number 200089, (order quantity of two per connector)
 - Kalrez, part number PA-06, kit of two O-rings, (order quantity of one kit per connector)
 - Perfrez, part number PA-07, kit of two O-rings, (order quantity of one kit per connector)
- New nozzle O-ring, part number 201153-C, (order quantity of one per connector)

*MTBR (Mean Time Between Replacement) – Average values for reference only. Actual frequency depends on usage, chemistry and proper installation.

Replacing the Probe O-rings

The two O-rings on the ErgoNOW connector probe (Figure 33) provide a seal between the connector and the interior of a connected bottle. Inspect the O-ring condition each time the connector is removed from a bottle and replace if worn or damaged.

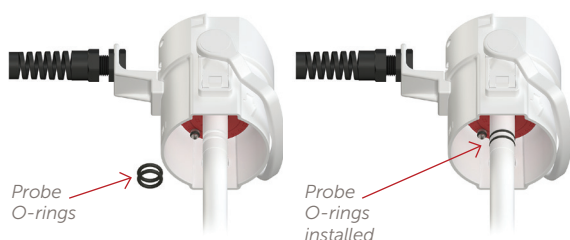

Figure 33. Replacing the probe O-rings.

NOTE: The probe O-rings may be changed without removing the gas inlet or liquid outlet lines from the ErgoNOW connector.

Follow these steps:

1. Wipe any excess chemical off the probe. Use appropriate personal protective equipment and cleaning supplies appropriate for the specific chemical contained in the bottle.
2. Using the O-ring pick, carefully lift the O-ring that is closest to the keyed retainer out of the groove. Slide it over the other O-ring and off the end of the probe.
3. Using the O-ring pick, carefully lift the remaining O-ring out of its groove and slide it off the end of the probe.
4. Clean any residue out of the O-ring grooves. Use cleaning supplies appropriate for the specific chemical in the bottle.
5. Inspect the two O-ring grooves. If there is any damage to the grooves that would prevent sealing, the ErgoNOW connector must be replaced.
6. Without twisting the O-ring, install the first new O-ring into the groove closest to the end of the probe.
7. Without twisting the O-ring, install the second new O-ring by carefully moving it over the first O-ring and into the groove closest to the keyed retainer.

Replacing the Nozzle O-ring

The nozzle O-ring (Figure 34) is located on the keyed retainer inside the ErgoNOW connector. It provides a seal between the gas inlet fitting and the nozzle port in the SmartCap or IntelliCap closure. Inspect the O-ring condition each time the connector is removed from a bottle, and replace if worn or damaged.

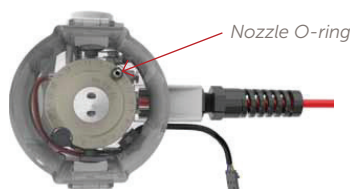

Figure 34. Replacing the nozzle O-ring (underside of ErgoNOW connector).

Follow these steps:

1. Wipe any excess chemical off the probe. Use appropriate personal protective equipment and cleaning supplies appropriate for the specific chemical in the NOWPak bottle.
2. Using the O-ring pick, carefully lift the O-ring out of the groove. Slide it over the end of the nozzle.
3. Clean any residue out of the O-ring groove. Use cleaning supplies appropriate for the specific chemical in the bottle.
4. Inspect the O-ring groove. If there is any damage to the groove that would prevent sealing, the keyed retainer may need to be replaced. See "Replacing the Keyed Retainer" on page 20.
5. Without twisting the O-ring, install the new O-ring into the groove.

O-ring Handling Guidelines

- Avoid twisting of O-rings. Twisted or incorrectly installed O-rings will reduce the ability of the O-ring to form a seal between the ErgoNOW connector and the NOWPak or PDMPak bottle and may result in leaks or inability to dispense.
- Use only tools specifically designed for O-ring handling. Special tools are available from Entegris, (part number NA-27). O-ring handling tools must be polished and are designed to prevent scratches.







- When removing or replacing O-rings, minimize contact with the ErgoNOW connector probe and avoid scratching the O-ring grooves.
- Stretch the O-ring uniformly and as little as possible during installation. Confirm that the O-ring is completely inserted and uniformly seated within the O-ring groove.
- Entegris replacement O-rings have been pre-cleaned. Additional cleaning is not necessary prior to use.
- To ensure proper fit and operation, use only Entegris replacement O-rings. Entegris is not responsible for damage or failure to operate as a result of using third party O-rings.

REPLACING THE KEYED RETAINER

The Keyed Retainer Replacement Kit (Figure 35) allows the end user to change the 6-digit key coding on ErgoNOW connectors when a chemical is changed. Replacement retainers are available in Delrin® (a polyoxymethylene material), Noryl® (a polyphenylene oxide material), Ultem™ 1000 (a polyetherimide [PEI] material), or PEEK (a polyether ether ketone material).

Specify the desired material and coding when ordering the replacement retainer part number. The wide notch designates the name of the chemical supplier, and the two narrow notches designate the chemical contained in the sealed bottle. Contact your Entegris Sales Account Manager for assistance in ordering the kit.

Following is a table containing the variety of replacement ErgoNOW replacement keyed retainer part numbers with their components.

PART NUMBER	PA-12-XXYYZZ*	PA-12-232122**	LKR-AA-XXYYZZ* (FOR PD-TYPE CONNECTOR)	PA-13-XXYYZZ* AND PA-13-232122**	PA-14-XXYYZZ* AND PA-14-232122**	PA-15-XXYYZZ* AND PA-15-232122**
Materials of Construction	Delrin	Delrin	Delrin	Noryl	Ultem 1000	PEEK
Contents	Retainer only	Retainer only	Retainer, stainless steel lock washers, EPDM nozzle O-ring, 1/4" retaining clip	Retainer only	Retainer only	Retainer only
Retainer color	Black	Red	Black	Black	Amber	Gray
Retainer image						

* XXYYZZ represents the customer-specific key code
 ** 232122 is the default key code

Use the following procedures to replace a keyed retainer in an ErgoNOW PL or PD connector with a new keyed retainer having the same or a different coding.

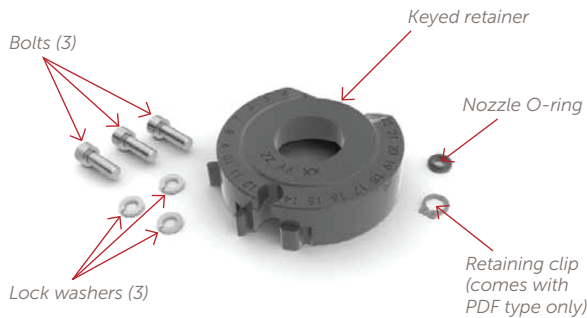

Figure 35. ErgoNOW keyed retainer replacement kit, part number LKR-AA-XXYYZZ*.

PL-type connector

Use this procedure to install the ErgoNOW keyed retainer replacement onto an ErgoNOW PL-type connector.

Tools required (see “Required Tools and Accessories” on page 28):

- 9/64” hex wrench
- O-ring pick, part number NA-27

Follow these steps:

1. Remove the two O-rings from the probe. Do this by pinching two sides of each O-ring. This creates slack allowing the O-rings to be pushed out of the channels.
2. Remove the gas inlet fitting from the ErgoNOW connector. Do this by inserting a flat-bladed screwdriver through the access hole in the ErgoNOW connector, as shown in Figure 36. Gently pry the quick connect fitting upward to release it.

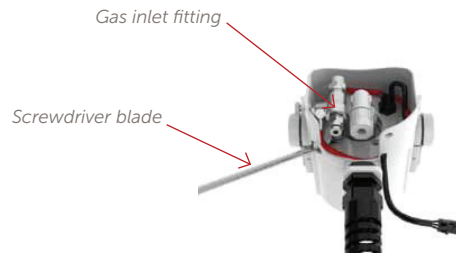

Figure 36. Using a screwdriver to remove the gas inlet fitting.

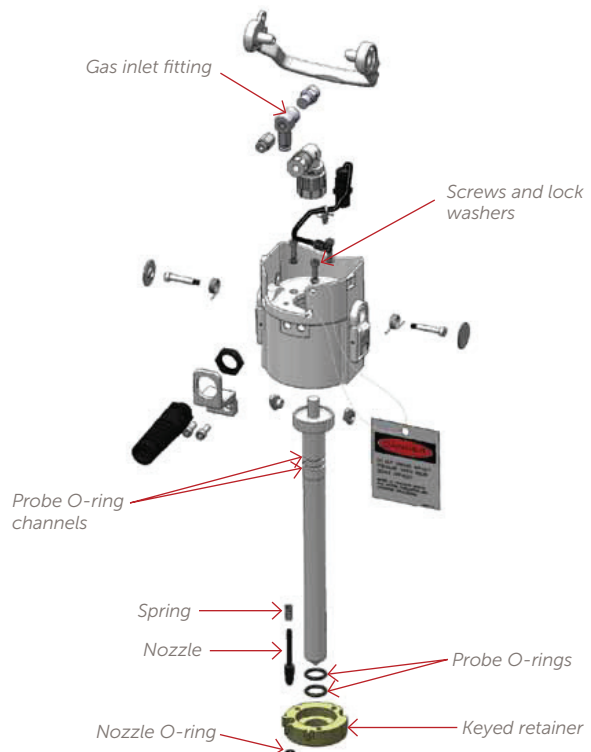

Figure 37. Removing and replacing the keyed retainer.

*XXYYZZ represents the customer-specific key code.

3. Use a $\frac{9}{64}$ " hex wrench to remove the three screws and lock washers from the top of the ErgoNOW connector.
4. Slide the keyed retainer down the length of the probe for removal.
5. Replace the current keyed retainer with the new one (see Figure 38).
 - a. Remove nozzle O-ring from nozzle, and discard.
 - b. Remove the nozzle and spring from the current keyed retainer.
 - c. Install the nozzle and existing spring onto the new keyed retainer.
 - d. Install the new nozzle O-ring onto the nozzle.



Figure 38. Removing and installing the nozzle, nozzle O-ring and spring.

6. Slide the new keyed retainer with nozzle up the probe and into the bottom of the ErgoNOW connector.
7. Align the keyed retainer so the notched portion of the keyed retainer is aligned with the sensor, and the pressure assist hole is aligned with the nozzle.
8. Using an inch-pound torque wrench with a $\frac{9}{64}$ " hex wrench, tighten the three screws with lock washers to 15 in•lb.
9. Reinstall the two probe O-rings.

NOTE: Inspect the probe O-rings for damage or excessive wear and replace if necessary.
10. Install the gas inlet fitting onto the nozzle. The quick connect fitting should "click" securely into place.

PD-type Connector

Use this procedure to install the ErgoNOW keyed retainer replacement onto an ErgoNOW PD-type connector.

NOTE: The procedure for replacing the keyed retainer on an ErgoNOW PD-type connector is identical to that for a PL-type connector, except that the PD-type connector contains a pneumatic cylinder held in place with a retaining clip. That cylinder must be removed and then reinstalled during the procedure. For PD-type connectors, use keyed retainer replacement kit part number LKR-AA-XXYYZZ*. This kit part number contains the required retaining clip.

Tools required (see "Required Tools and Accessories" on page 28):

- 9/64" hex wrench
- O-ring pick, part number NA-27
- Snap ring pliers (see Figure 39)



Figure 39. Snap ring pliers.

Follow these steps:

1. Remove the two O-rings from the probe. Do this by pinching two sides of each O-ring. This creates slack allowing the O-rings to be pushed out of the channels.
2. Remove the gas inlet fitting from the ErgoNOW connector. Do this by inserting a flat-bladed screwdriver through the access hole in the ErgoNOW connector as shown in Figure 40. Gently pry the quick connect fitting upward to release it.

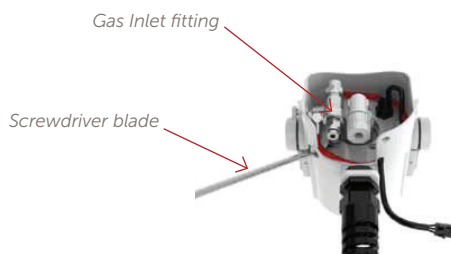

Figure 40: Using a screwdriver to remove the gas inlet fitting.

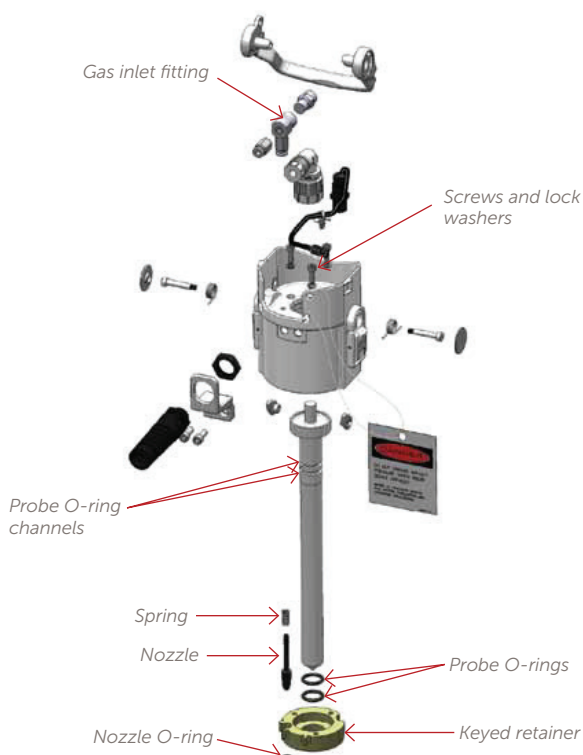

Figure 41. Removing and replacing the keyed retainer.

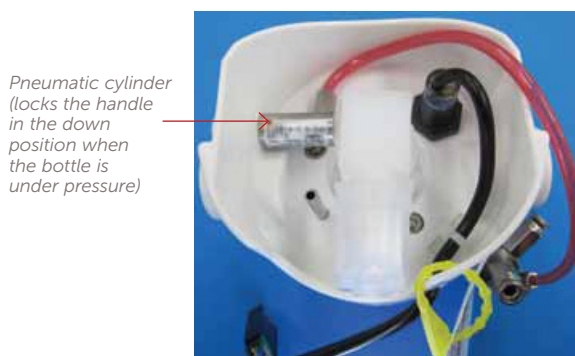

Figure 42. Location of pneumatic cylinder inside ErgoNOW connector.

*XXYYZZ represents the customer-specific key code.

3. The pneumatic locking cylinder (Figure 42) is located directly above one of the screws and must be removed from the connector body:
 - a. Hold the connector handle in the vertical position to gain access to the retaining clip which holds the cylinder in place (see Figure 43).
 - b. Use the snap ring pliers to remove the retaining clip. Do this by placing the pliers pins into the two small holes on the clip, as shown in Figure 43. Squeeze the pliers to release the clip.



Figure 43. Using the snap ring pliers to remove the retaining clip.

- c. The cylinder is now free to be removed from the connector body. Remove the cylinder to gain access to the screw (see Figure 44).

NOTE: Discard the removed retaining clip. When reinstalling the cylinder, use the new clip provided in the LKR-AA-XXYYZZ* Keyed Retainer Replacement Kit.

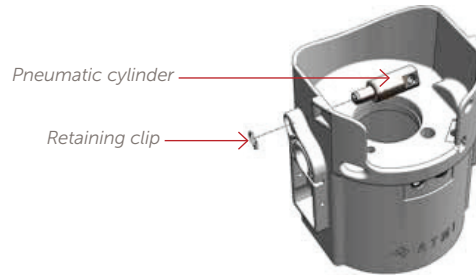

Figure 44. Pneumatic cylinder and retaining clip assembly.

4. Use a $\frac{9}{64}$ " hex wrench to remove the three screws and lock washers from the top of the ErgoNOW connector.
5. Slide the keyed retainer down the length of the probe for removal.
6. Replace the current keyed retainer with the new one (see Figure 45).
 - a. Remove nozzle O-ring from nozzle and discard.
 - b. Remove the nozzle and spring from the current keyed retainer.
 - c. Install the nozzle and existing spring onto the new keyed retainer.
 - d. Install the new nozzle O-ring onto the nozzle.



Figure 45. Removing and installing the nozzle, nozzle O-ring and spring.

*XXYYZZ represents the customer-specific key code.

7. Slide the new keyed retainer with nozzle up the probe and into the bottom of the ErgoNOW connector.
8. Align the keyed retainer so the notched portion of the keyed retainer is aligned with the sensor, and the pressure assist hole is aligned with the nozzle.
9. Using an inch-pound torque wrench with a $\frac{9}{64}$ " hex wrench, tighten the three screws with lock washers to 15 in•lb.
10. Reinstall the two probe O-rings.

NOTE: Inspect the probe O-rings for damage or excessive wear and replace if necessary.

11. Install the pneumatic cylinder onto the connector body:
 - a. Put the cylinder back into place inside the ErgoNOW connector (see Figure 46).
 - b. Use the snap ring pliers to install a new retaining clip (included with the Keyed Retainer Replacement Kit) onto the cylinder to fix it in place (see Figure 47).



Figure 46. Installing the pneumatic cylinder.



Figure 47. Installed retaining clip.

12. Install the gas inlet fitting onto the nozzle. The quick connect fitting should “click” securely into place.

SECTION 7: TROUBLESHOOTING

Use the following table to troubleshoot any problems that occur with the ErgoNOW connector and NOWPak or PDMPak liner-based bottle system.

If problems exist that are not covered in this section or if these solutions do not resolve the problem, contact your Entegris Sales Account Manager for assistance.

⚠ WARNING: Follow all chemical safety procedures and wear chemical splash goggles and other appropriate personal protective equipment when handling components containing chemicals.

⚠ WARNING: Troubleshooting the ErgoNOW connector should be performed only after venting the pressure between the liner and the bottle. Troubleshooting while the ErgoNOW connector is connected to a pressurized bottle may result in injury to the operator and/or damage to the connector.



SYMPTOM	CAUSE	CORRECTIVE ACTION
Pressure dispense gas system leak	Leak at pressure gas fittings/connections	Vent the pressure dispense gas system. Inspect all air fittings for loose or faulty connections. Re-pressurize the system and check for leaks. If a leak is detected, vent pressure and tighten faulty connection. If no leaks are detected, vent pressure and check that the ErgoNOW connector body is correctly installed onto the bottle/closure assembly and clicked into place. Re-pressurize the system and check for leaks.
	Leak at the nozzle between the ErgoNOW connector and the closure	Check the nozzle O-ring for damage. If O-ring is damaged, replace with a new O-ring. Re-pressurize the system and check for leaks.
	Loose closure causing a leak at the seal between the ErgoNOW connector and NOWPak bottle, or between the fitment and the closure	Remove the ErgoNOW connector from the bottle/closure assembly. Ensure that the closure is tightened onto the bottle/closure assembly. Re-pressurize the system and check for leaks.
	Liner damage resulting in dispense failure	Contact your Entegris Sales Account Manager.



SYMPTOM	CAUSE	CORRECTIVE ACTION
System overpressurization	Pressure relief valve malfunction	<p>The pressure relief valve nominal cracking pressure is 7 psig (for PL-type) and 20 psig (for PD-type) dispense connectors.</p> <p>⚠ WARNING: If the pressure exceeds these levels, immediately switch off the gas inflow at an upstream source.</p>
	Leaking at the liquid outlet fitting	<p>Vent the pressure dispense gas system.</p> <p>Tighten the fitting nut as per the fitting manufacturer's standard procedure.</p> <p>Re-pressurize the system and check for leaks.</p>
Chemical leak	Leaking at the probe O-ring seal	<p>Replace the probe O-rings. See Section 6, System Maintenance.</p>
	Leaking at the liquid outlet fitting	<p>Vent the pressure dispense gas system.</p> <p>Tighten the fitting nut as per the fitting manufacturer's standard procedure.</p> <p>Re-pressurize the system and check for leaks.</p>
Release lever does not lift to release the ErgoNOW connector (PD only)	Locking cylinder is engaged	<p>Verify the locking cylinder has not retracted. Verify the pressure has been vented from the system.</p> <p>With the release lever in the down position, use a tool equal or less than 5.08 mm (0.200") to push the pin back into the retracted state.</p> <p>Disconnect the ErgoNOW connector from the NOWPak bottle.</p> <p>Testing the locking cylinder function: With the release lever in the up position, apply pressure to the air inlet fitting and verify the locking cylinder is engaged.</p> <p>Remove the pressure and verify the locking cylinder is retracted.</p> <p>If the locking cylinder does not engage when pressure is applied and retracted when pressure is relieved, a malfunction has occurred. Contact your Entegris Sales Account manager.</p>
	Locking cylinder is engaged	<p>Verify the locking cylinder has not retracted. Verify the pressure has been vented from the system.</p> <p>With the release lever in the down position, use a tool equal or less than 5.08 mm (0.200") to push the pin back into the retracted state.</p> <p>Disconnect the ErgoNOW connector from the NOWPak bottle.</p> <p>Testing the locking cylinder function: With the release lever in the up position, apply pressure to the air inlet fitting and verify the locking cylinder is engaged.</p> <p>Remove the pressure and verify the locking cylinder is retracted.</p> <p>If the locking cylinder does not engage when pressure is applied and retracted when pressure is relieved, a malfunction has occurred. Contact your Entegris Sales Account manager.</p>
Release lever does not return to the down position	Torsion spring broken	<p>If the torsion spring is broken, contact your Entegris Sales Account Manager.</p>
	Torsion spring disconnected from release lever	<p>Move the end of the torsion spring onto the release lever.</p>
Locking cylinder does not engage	Locking cylinder malfunction	<p>Verify the release lever is in the down position. Verify the pressure has been applied to the ErgoNOW connector and it is pressurized.</p>
Failure of sensor to illuminate	Broken wires	<p>Verify the wires are not broken or damaged. If wires are broken, the connector will need to be replaced. Contact your Entegris Sales Account Manager.</p>
	Sensor not connected	<p>Verify the sensor is correctly seated and not loose in the ErgoNOW connector.</p>

APPENDIX A: REQUIRED TOOLS AND ACCESSORIES

Specialized tools from Entegris are required for filling, operation and maintenance of the ErgoNOW connector and NOWPak and PDMPak liner-based bottle system. The item number and names of these tools are listed below.

Contact Entegris to order these tools.

TOOL	PART NUMBER	DESCRIPTION	PHOTO OR ILLUSTRATION
Tear tab removal tool	NA-47	Tool for removing the tear tab from SmartCap or IntelliCap closure, Delrin	
Tear tab removal tool	NA-47-SS	Tool for removing the tear tab from SmartCap or IntelliCap closure, stainless steel	
O-ring removal tool kit	NA-27	Selection of O-ring picks and tools	

ACCESSORIES AND REPLACEMENT PARTS	ITEM NO.	DESCRIPTION	PHOTO OR ILLUSTRATION
Keyed retainer	PA-12-XXYYZZ	Kit, retainer only, Delrin	
	PA-12-232122	Kit, retainer only, Delrin (default key code)	
	LKR-AA-XXYYZZ	Kit, keyed retainer, Delrin (contains keyed retainer, hardware, nozzle O-ring, and retaining clip) – required for updating the PD-type ErgoNOW connector	
Keyed retainer	PA-13-XXYYZZ	Kit, retainer only, Noryl	
	PA-13-232122	Kit, retainer only, Noryl (default key code)	

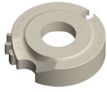
ACCESSORIES AND REPLACEMENT PARTS	ITEM NO.	DESCRIPTION	PHOTO OR ILLUSTRATION
Keyed retainer	PA-14-XXYYZZ	Kit, retainer only, Ultem 1000	
	PA-14-232122	Kit, retainer only, Ultem 1000 (default key code)	
Keyed retainer	PA-15-XXYYZZ	Kit, retainer only, PEEK	
	PA-15-232122	Kit, retainer only, PEEK (default key code)	
Gas inlet fitting kit	PA-09-AX	Gas inlet fitting assembly option A, for ErgoNOW connector	
O-ring	PA-06	Kit, replacement probe O-ring, Kalrez, quantity of two	
O-ring	PA-07	Kit, replacement probe O-ring, Perfrez, quantity of two	
O-ring	200089	Replacement probe O-ring, Chemraz, quantity of one (two replacement probe O-rings are required per connector)	
O-ring	201153-C	Replacement nozzle O-ring, EPDM, quantity of one	
Gas fitting	400765-C	Gas fitting component, stainless steel bulkhead adaptor fitting for 1/8", New-Machine, cleaned	
Shouldered nozzle	401209-C	Replacement, stainless steel shouldered nozzle	

LIMITED WARRANTY

Entegris' products are subject to the Entegris, Inc. General Limited Warranty. To view and print this information, visit entegris.com and select the [Legal & Trademark Notices](#) link in the footer. Entegris does not warrant any failure in the case of customers using unapproved foreign components.

FOR MORE INFORMATION

Please call your Regional Customer Service Center today to learn what Entegris can do for you. Visit entegris.com and select the [Contact Us](#) link to find the customer service center nearest you.

TERMS AND CONDITIONS OF SALE

All purchases are subject to Entegris' Terms and Conditions of Sale. To view and print this information, visit entegris.com and select the [Terms & Conditions](#) link in the footer.



Corporate Headquarters

129 Concord Road
Billerica, MA 01821
USA

Customer Service

Tel +1 952 556 4181
Fax +1 952 556 8022
Toll Free 800 394 4083

Entegris®, the Entegris Rings Design®, and other product names are trademarks of Entegris, Inc. as listed on entegris.com/trademarks. All third-party product names, logos, and company names are trademarks or registered trademarks of their respective owners. Use of them does not imply any affiliation, sponsorship, or endorsement by the trademark owner.

©2024 Entegris, Inc. | All rights reserved. | Printed in the USA | 7119-13091ENT-0824