

FluoroLine® Plus Dual Containment Tubing

Enabling uninterrupted process lines and increased chemical resistance at lower cost per installed foot of tubing

Clean, Continuous Lengths

Entegris offers ultraclean FluoroLine® Plus dual containment tubing for use in high-purity sub-fab applications. This innovative product allows long, continuous double-contained tubing lengths without the introduction of contaminants common when pulling tubing through traditional PVC secondary containment. For extreme purity needs, this ultraclean tubing has the lowest total metal extractables and least amount of surface contamination.

PFA Primary Containment

Entegris offers three grades of ultrapure FluoroLine PFA tubing for primary containment: high-purity HP PFA plus, high-purity high molecular weight (HMW) PFA, and high-purity PFA. Each is made from 100% virgin PFA material and is ideal for use in high-purity, highly corrosive applications. PFA primary containment tubing is available in ¼", ⅜", ½", ¾", 1", 1¼", and 40 mm sizes.

Special Blend PFA Secondary Containment

FluoroLine Plus PFA tubing comprises the secondary containment in Entegris' dual containment tubing. This special blend PFA material offers improved chemical resistance at a lower cost, and provides clarity for easy visual inspection of primary tubing. Unlike rigid PVC pipe, which is commonly used for secondary containment, FluoroLine Plus PFA tubing is flexible and bends easily. No heat bending containment pipe or tensile pulling primary tubing is required during installation. FluoroLine Plus PFA secondary containment is available in ½", ¾", 1", 1⅜", 40 mm, and 2" sizes.

Fast and Easy Installation

FluoroLine Plus dual containment tubing can be installed or retrofitted in mere hours instead of days. This enables time-saving installation into areas highly populated with other facility

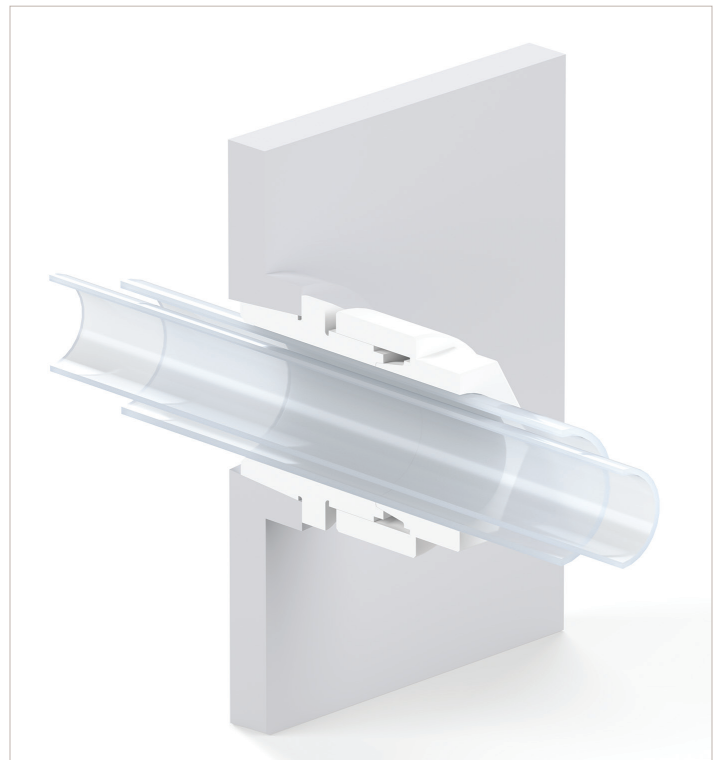

Extrusion process reduces contamination potential and enables long, continuous lengths.

plumbing or facility infrastructure where it is difficult to route rigid PVC containment pipe. Because Entegris' dual containment tubing is available in long, continuous lengths, you no longer have to weld PVC pipe sections together to create the secondary containment system. In addition, the primary tubing does not need to be pulled through PVC pipe on-site, dramatically reducing installation and labor cost.

APPLICATIONS

- Tool hookup and primary distribution lines in bulk chemical delivery sub-fab applications
- Specialty chemical manufacturing in corrosive chemical environments
- TFT/LCD processes requiring corrosive chemical handling

FEATURES & BENEFITS

PFA primary containment	Broad chemical compatibility
Special blend of FluoroLine Plus PFA secondary containment	More chemically compatible than competitive secondary containment tubing materials Low cost
Tube-in-tube design	Long, continuous lengths are possible without connections or welding Faster, less labor-intensive installation Considerable total cost reduction per foot of installed tubing Additional tool hookup lines can be added in hours, not days
Flexible tubing	No tensile pulls are introduced on tubing Does not kink as result of pulling through PVC secondary containment No special and expensive welding or heat bending processes are required
Laser marking on both inner and outer tubing	Enables traceability to the work order and inspection record

TUBING ORDERING INFORMATION

FluoroLine Plus primary tubing has the same pressure and temperature specifications as FluoroLine ultrapure, single line tubing. For pressure and temperature ratings of FluoroLine tubing, visit Entegris' Web site at www.entegris.com/products/fluidmanagement. Minimum order quantities may apply. Contact Entegris, Inc. for additional information.

FluoroLine Plus dual containment tubing has three process line material options:

- FluoroLine UATUC (UC) = Chemours 405HP
- FluoroLine XKTUC (KC) = Daikin AP231SH
- FluoroLine UMTUC (UMC) = 3M 6502UHPZ

Part number	Tube size	Maximum reel length
DCT500F-250* Process line Secondary containment line	1/4" 1/2"	1219 m (4000')
DCT750F-375* Process line Secondary containment line	3/8" 3/4"	457 m (1500')
DCT750F-500* Process line Secondary containment line	1/2" 3/4"	457 m (1500')
DCT1000F-500* Process line Secondary containment line	1/2" 1"	229 m (750')
DCT1000F-750* Process line Secondary containment line	3/4" 1"	229 m (750')
DCT1375F-1000* Process line Secondary containment line	1" 1 3/8"	183 m (600')
DCT1570F-1250* Process line Secondary containment line	1 1/4" 40 mm	152 m (500')
DCT2000F-1570* Process line Secondary containment line	40 mm 2"	152 m (500')

*Tube size and reel length are the same regardless of tubing material (UAT, XKT, UMT). The process line is also available in other PFA material grades as a special order. To order, contact Entegris.

Part number	OD	OD tolerance	ID	Wall thickness	Wall thickness tolerance	Minimum bend radius
DCT500F-250*						
Process line	6.35 mm (0.250")	±0.102 mm (±0.004")	3.96 mm (0.156")	1.19 mm (0.047")	±0.10 mm (±0.004")	38 mm (1.5")
Secondary containment line	12.70 mm (0.500")	±0.127 mm (±0.005")	9.55 mm (0.376")	1.57 mm (0.062")	±0.13 mm (±0.005")	70 mm (2.8")
DCT750F-375*						
Process line	9.52 mm (0.375")	±0.102 mm (±0.004")	6.38 mm (0.251")	1.57 mm (0.062")	±0.13 mm (±0.005")	51 mm (2.0")
Secondary containment line	19.05 mm (0.750")	±0.127 mm (±0.005")	15.90 mm (0.626")	1.57 mm (0.062")	±0.13 mm (±0.005")	229 mm (9.0")
DCT750F-500*						
Process line	12.70 mm (0.500")	±0.127 mm (±0.005")	9.55 mm (0.376")	1.57 mm (0.062")	±0.13 mm (±0.005")	58 mm (2.3")
Secondary containment line	19.05 mm (0.750")	±0.127 mm (±0.005")	15.90 mm (0.626")	1.57 mm (0.062")	±0.13 mm (±0.005")	229 mm (9.0")
DCT1000F-500*						
Process line	12.70 mm (0.500")	±0.127 mm (±0.005")	9.55 mm (0.376")	1.57 mm (0.062")	±0.13 mm (±0.005")	58 mm (2.3")
Secondary containment line	25.40 mm (1.000")	±0.127 mm (±0.005")	22.25 mm (0.876")	1.57 mm (0.062")	±0.13 mm (±0.005")	79 mm (11.0")
DCT1000F-750*						
Process line	19.05 mm (0.750")	±0.127 mm (±0.005")	15.90 mm (0.626")	1.57 mm (0.062")	±0.13 mm (±0.005")	229 mm (9.0")
Secondary containment line	25.40 mm (1.000")	±0.127 mm (±0.005")	22.25 mm (0.876")	1.57 mm (0.062")	±0.13 mm (±0.005")	279 mm (11.0")
DCT1375F-1000*						
Process line	25.40 mm (1.000")	±0.127 mm (±0.005")	22.25 mm (0.876")	1.57 mm (0.062")	±0.13 mm (±0.005")	279 mm (11.0")
Secondary containment line	34.93 mm (1.375")	±0.178 mm (±0.007")	31.12 mm (1.225")	1.57 mm (0.062")	±0.18 mm (±0.007")	457 mm (18.0")
DCT1570F-1250*						
Process line	31.75 mm (1.25")	±0.18 mm (±0.007")	27.94 mm (1.100")	1.91 mm (0.075")	±0.18 mm (±0.007")	318 mm (12.5")
Secondary containment line	40 mm (1.57")	±0.18 mm (±0.007")	36.73 mm (1.446")	1.57 mm (0.062")	±0.20 mm (±0.008")	572 mm (22.5")
DCT2000F-1570*						
Process line	40.00 mm (1.570")	±0.18 mm (±0.007")	36.73 mm (1.446")	2.18 mm (0.086")	±0.18 mm (±0.007")	572 mm (22.5")
Secondary containment line	50.84 mm (2.000")	±0.20 mm (±0.008")	45.57 mm (1.794")	2.62 mm (0.103")	±0.20 mm (±0.008")	635 mm (25.0")

*Values are the same regardless of process line material options.

Laser Marking Codes

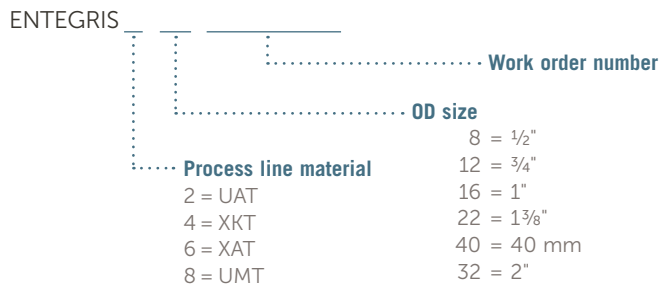

Dual Containment Tubing Cutter

Entegris has designed a special tube cutter that cuts the secondary containment without damaging the primary tubing, reducing potential rework.

Part number	Secondary containment tubing
213-203-N	1/2" OD
213-204-N	3/4" OD
213-205-N	1" OD
213-221-N	1 3/8" OD
213-218-N	40 mm OD
213-222-N	2" OD



Entegris' tube cutter delicately scores the secondary containment tubing without penetrating the primary tubing. Once scored, simply snap it off.

PASS-THROUGH PFA DUAL CONTAINMENT FITTINGS

Fewer Connections, Fewer Leak Points

Entegris offers molded PFA dual containment fittings that enable a process line to pass through walls uninterrupted. The pass-through dual containment fitting was designed around Entegris' industry leading Flaretek® and Quikgrip® fittings. These high-performing extensions of Entegris' proven fitting technologies offer fewer connections, easier assembly, and fewer leak points.

Uninterrupted Tubing Runs

This fitting is the only fitting on the market to offer true dual containment from one box to the next. The advanced fitting enables a process line to pass through a wall to the next component uninterrupted. Special corrugated tubing is not required

for secondary containment, thus enabling the use of standard, straight-wall tubing, and providing a great cost advantage. In addition, the dual containment fitting has an O-ring that seals off the fitting at the cabinet wall. This seal prevents fluid from escaping through the panel mount hole, maintaining cabinet integrity in the event of a leak, and increasing safety to a level unmatched by competitive fittings.

Reduce Contamination, Increase Safety

Flaretek and Quikgrip dual containment fittings support $\frac{1}{4}$ " to $\frac{3}{4}$ " process lines, with secondary lines from $\frac{1}{2}$ " to 1". Integral ferrule dual containment fittings support up to 40 mm process lines with up to 2" secondary lines. The fitting assemblies adapt to panels that are up to $\frac{1}{2}$ " thick.

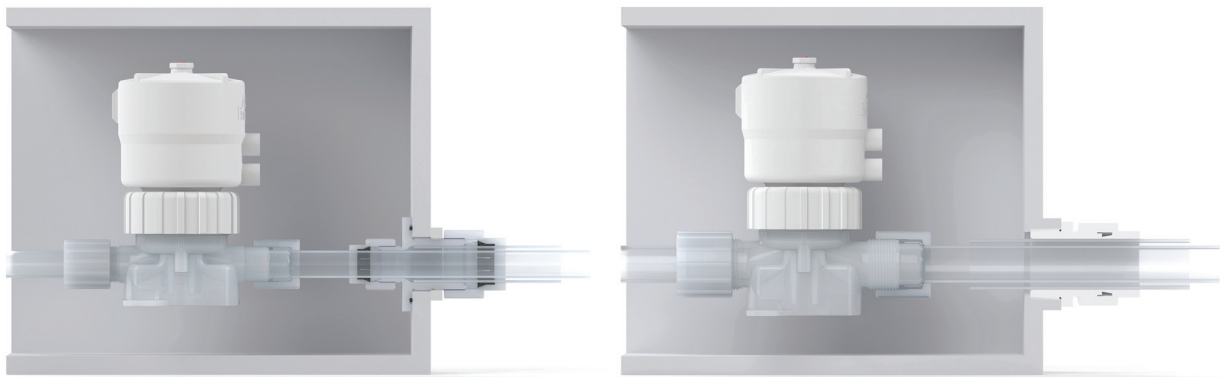

Dual containment fittings enable uninterrupted tubing runs.

FITTING ORDERING INFORMATION

Dual Containment Flaretek x Quikgrip

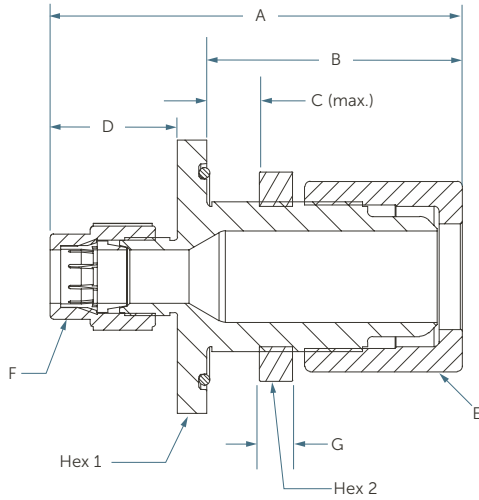

Flaretek x Quikgrip

Part number	Process line (F)	Secondary containment line (E)	DIMENSIONS							Panel mount hole diameter
			A	B	C	D	G	Hex 1	Hex 2	
DCC8F-4GN*	1/4" Quikgrip	1/2" Flaretek	85.6 mm (3.37")	52.3 mm (2.06")	12.7 mm (0.50")	26.2 mm (1.03")	8.1 mm (0.32")	1 3/8"	1 1/16"	19.0 mm (0.75")
DCC12F-6GN*	3/8" Quikgrip	3/4" Flaretek	95.8 mm (3.77")	59.9 mm (2.36")	12.7 mm (0.50")	28.7 mm (1.13")	9.7 mm (0.38")	1 3/8"	1 5/16"	25.4 mm (1.00")
DCC12F-8GN*	1/2" Quikgrip	3/4" Flaretek	97.8 mm (3.85")	59.9 mm (2.36")	12.7 mm (0.50")	30.7 mm (1.21")	9.7 mm (0.38")	1 3/8"	1 5/16"	25.4 mm (1.00")
DCC16F-8GN*	1/2" Quikgrip	1" Flaretek	99.6 mm (3.92")	61.7 mm (2.43")	12.7 mm (0.50")	30.7 mm (1.21")	8.1 mm (0.32")	2 1/4"	1 3/4"	38.1 mm (1.50")
DCC16F-12GN*	3/4" Quikgrip	1" Flaretek	104.9 mm (4.13")	61.7 mm (2.43")	12.7 mm (0.50")	36.1 mm (1.42")	8.1 mm (0.32")	2 1/4"	1 3/4"	38.1 mm (1.50")

* = PFA body with -1 (PVDF), -3 (PFA), or -6 (CPFA) nuts.

FITTING ORDERING INFORMATION (CONTINUED)

Dual Containment Quikgrip × Quikgrip

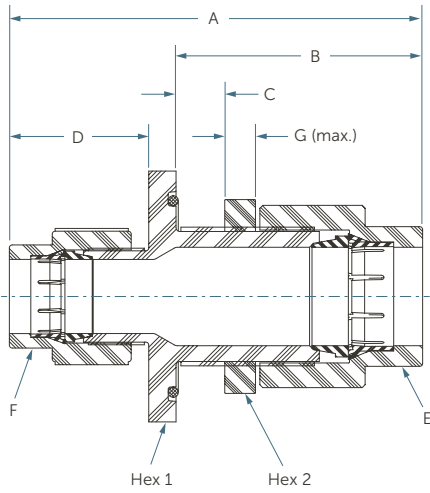

Quikgrip × Quikgrip

Part number	Process line (F)	Secondary containment line (E)	DIMENSIONS					Hex 1	Hex 2	Panel mount hole diameter
			A	B	C	D	G			
DCC8G-4GN-1M	¼" Quikgrip	½" Quikgrip	82.6 mm (3.25")	49.5 mm (1.95")	12.7 mm (0.50")	26.2 mm (1.03")	8.1 mm (0.32")	1⅜"	1½"	19.0 mm (0.75")
DCC12G-8GN-1M	½" Quikgrip	¾" Quikgrip	94.7 mm (3.73")	57.7 mm (2.27")	12.7 mm (0.50")	30.7 mm (1.21")	9.7 mm (0.38")	1⅝"	1⅞"	25.4 mm (1.00")
DCC16G-12GN-1M	¾" Quikgrip	1" Quikgrip	108.2 mm (4.26")	64.3 mm (2.53")	12.7 mm (0.50")	36.1 mm (1.42")	8.1 mm (0.32")	2¼"	1¾"	38.1 mm (1.50")

FITTING ORDERING INFORMATION (CONTINUED)

Dual Containment Integral Ferrule x Integral Ferrule

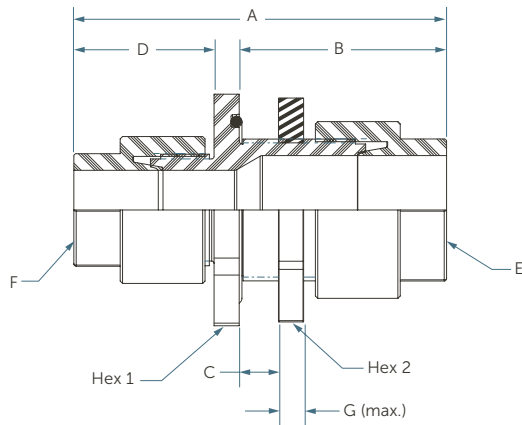

Integral Ferrule x Integral Ferrule

Part number	Process line (F)	Secondary containment line (E)	DIMENSIONS					Hex 1	Hex 2	Panel mount hole diameter
			A	B	C	D	G			
DCC22N-16N*	1" Integral Ferrule	1 3/8" Integral Ferrule	121.4 mm (4.78")	67.8 mm (2.67")	12.7 mm (0.50")	45.5 mm (1.79")	8.1 mm (0.32")	2 5/8"	2 1/2"	47.8 mm (1.88")

*Fitting body and integral ferrule nut are polyethylene (PE) material.

FITTING ORDERING INFORMATION (CONTINUED)

Dual Containment Integral Ferrule x MNPT

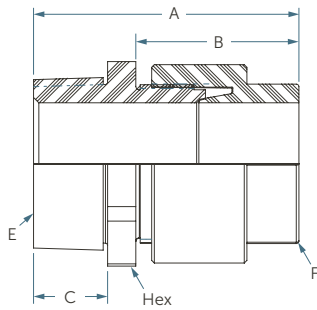

Integral Ferrule x MNPT

Part number	Process line	Secondary containment line	DIMENSIONS					
			A	B	C	End connection E	End connection F	Hex
DCC22N-24MNPT	1"	1 $\frac{3}{8}$ "	76.5 mm (3.01")	47.0 mm (1.85")	21.3 mm (0.84")	1 $\frac{1}{2}$ " MNPT	1 $\frac{3}{8}$ " Integral Ferrule	50.8 mm (2.00")
DCCM40N-32MNPT	1 $\frac{1}{4}$ "	40 mm	73.7 mm (2.90")	46.2 mm (1.82")	19.3 mm (0.76")	2" MNPT	40 mm Integral Ferrule	69.9 mm (2.75")
DCC32N-40MNPT	40 mm	2"	106.2 mm (4.18")	61.2 mm (2.41")	29.0 mm (1.14")	2 $\frac{1}{2}$ " MNPT	2" Integral Ferrule	82.6 mm (3.25")

FOR MORE INFORMATION

Please call your Regional Customer Service Center today to learn what Entegris can do for you. Visit entegris.com and select the [Contact Us](#) link to find the customer service center nearest you.

TERMS AND CONDITIONS OF SALE

All purchases are subject to Entegris' Terms and Conditions of Sale. To view and print this information, visit entegris.com and select the [Terms & Conditions](#) link in the footer.



Corporate Headquarters

129 Concord Road
Billerica, MA 01821
USA

Customer Service

Tel +1 952 556 4181
Fax +1 952 556 8022
Toll Free 800 394 4083

Entegris®, the Entegris Rings Design®, and other product names are trademarks of Entegris, Inc. as listed on entegris.com/trademarks. All third-party product names, logos, and company names are trademarks or registered trademarks of their respective owners. Use of them does not imply any affiliation, sponsorship, or endorsement by the trademark owner.

©2002-2021 Entegris, Inc. | All rights reserved. | Printed in the USA | 3130-10005ENT-0721